



*Operator's Manual  
& Parts Drawings*

# ED202

*Edger*





View all manuals



Visit [ventrac.com/manuals](http://ventrac.com/manuals) for the latest version of this operator's manual.

A downloadable parts manual is also available.

500 Venture Drive  
Orrville Oh 44667  
[www.ventrac.com](http://www.ventrac.com)

### To the Owner Contact Information and Product Identification

If you need to contact an authorized Ventrac dealer for information on servicing your product, always provide the product model and serial numbers.

*Please fill in the following information for future reference. See the picture(s) below to find the location of the identification numbers. Record them in the spaces provided.*

Date of Purchase: \_\_\_\_\_

Dealer: \_\_\_\_\_

Dealer Address: \_\_\_\_\_

Dealer Phone Number: \_\_\_\_\_

Dealer Fax Number: \_\_\_\_\_

<p>Model # (A): _____</p> <p>Serial # (B): _____</p> <p>Affix Part/Serial Number label here.</p>
--



Venture Products Inc. reserves the right to make changes in design or specifications without obligation to make like changes on previously manufactured products.

# TABLE OF CONTENTS

<b>INTRODUCTION</b>	<b>PAGE 5</b>
Product Description .....	5
Why Do I Need an Operator's Manual? .....	5
Using Your Manual .....	6
Manual Glossary .....	6
<b>SAFETY</b>	<b>PAGE 7</b>
Safety Decals .....	7
General Safety Procedures .....	8
Training Required .....	8
Personal Protective Equipment Requirements .....	8
Operation Safety .....	8
Preventing Accidents .....	9
Keep Riders Off .....	9
Operating On Slopes .....	10
Roadway Safety .....	10
Truck Or Trailer Transport .....	10
Maintenance .....	11
Fuel Safety .....	11
Hydraulic Safety .....	12
<b>EDGER SETUP &amp; CONFIGURATION</b>	<b>PAGE 14</b>
Edger Configurations .....	14
Normal Edging Setup (Disc Concave Facing Toward Frame) .....	14
Bed Shaping Setup (Disc Concave Facing Away From Frame) .....	14
Disc Position Setup .....	15
Disc Edger Extension .....	15
Setup For Left Side Operation .....	16
<b>GENERAL OPERATION</b>	<b>PAGE 17</b>
Daily Inspection .....	17
Attaching .....	17
Detaching .....	17
Operating Procedure .....	17
Edger Disc Angle Adjustment .....	18
Edger Cutting Depth Adjustment .....	18
Discharge Direction Adjustment For Optional Blower Fan .....	19
<b>SERVICE</b>	<b>PAGE 20</b>
Cleaning and General Maintenance .....	20
Tire Pressure .....	20
Lubrication Locations .....	20
Belt Inspection (Optional Blower Kit) .....	20
Attachment Drive Belt Replacement .....	20
Fan Drive Belt Replacement .....	21
Storage .....	21
Maintenance Schedule .....	22
Maintenance Checklist .....	22

# TABLE OF CONTENTS

---

<b>SPECIFICATIONS</b>	<b>PAGE 23</b>
Dimensions .....	23
Features .....	23
<b>PARTS</b>	<b>PAGE 24</b>
Main Frame .....	24
Gauge Wheel .....	26
Disc Mount Frame .....	28
Optional Blower Frame & Inlet Screens .....	30
Optional Blower Housing .....	32
Optional Blower Drive Frame & Shields .....	34
Optional Blower Drive Shaft .....	36
Optional Blower Fan (D-Hex Spline Pulley & Spindle Shaft) .....	38
<b>WARRANTY</b>	<b>PAGE 40</b>

# INTRODUCTION



Venture Products Inc. is pleased to provide you with your new Ventrac ED202 edger! We hope that Ventrac equipment will provide you with a ONE Tractor Solution.

Listed below are just some of the items that can provide you *versatility* as you use your ED202. Please visit our website, or contact your authorized Ventrac dealer for a complete list of items available for your new ED202 edger.

	Item Description	Part Number
Accessories	Blower Kit (4000 series power units only)	70.8020
	Ventrac weight (maximum of three)	47.0115
	Flat Free Tire.Wheel Assembly	53.0148

## Product Description

The Ventrac ED202 edger is designed for the sole purpose of edging along sidewalks, curbs, and cart paths, as well as edging and maintaining flower and mulch beds. Edging can be done on either the right or left side of the power unit per the operator's choice. The cutting disc can be reversed for bed shaping.

The multi-position swivel wheel can be adjusted to various heights to follow a variety of terrain.

For edging in hard ground, three 42 pound (19 kg) weights may be added to the weight bar on the disc guard.

For maximum productivity and performance, a bidirectional blower can be added when using the edger with a 4000 series power unit. This allows the operator to edge and blow debris from the area being edged in one efficient pass. The blower has multiple positions including right, left, or down which adds to its versatility.

## Why Do I Need an Operator's Manual?

This manual has been created to help you gain the important knowledge of what is needed to safely operate, maintain, and service your machine. It is divided into sections for convenient reference of the appropriate section.

You must read and understand the operator's manual for each piece of Ventrac equipment you own. Reading the operator's manual will help you become familiar with each specific piece of equipment. Understanding the operator's manual will help you, as well as others, avoid personal injury and/or damage to the equipment. Keep this manual with the machine at all times. The manual should remain with the machine even if it is sold. If this manual becomes damaged or unreadable, it should be replaced immediately. Contact your local Ventrac dealer for a replacement.

When using a Ventrac attachment, be sure to read and follow the safety and operating instructions of both the power unit and the attachment being used to ensure the safest operation possible.

The information in this manual provides the operator with the safest procedures to operate the machine while getting the maximum use out of the unit. Failure to follow the safety precautions listed in this manual may result in personal injury and/or damage to the equipment.

# INTRODUCTION

---

## Using Your Manual

Throughout this manual, you will encounter special messages and symbols that identify potential safety concerns to help you as well as others avoid personal injury or damage to the equipment.

### SYMBOL DEFINITIONS



#### **ATTENTION**

This symbol identifies potential health and safety hazards. It marks safety precautions. Your safety and the safety of others is involved.

There are three signal words that describe the level of safety concern: Danger, Warning, and Caution. Safety should always be the #1 priority when working on or operating equipment. Accidents are more likely to occur when proper operating procedures are not followed or inexperienced operators are involved.

Note: Right-Hand and Left-Hand orientations may be referred to at different places throughout this manual. Right-Hand and Left-Hand is determined as if sitting on the power unit seat facing forward.

### SIGNAL WORD DEFINITIONS

#### **⚠ DANGER**

Indicates an imminently hazardous situation which, if not avoided, will result in death or serious injury. This signal word is limited to the most extreme cases.

#### **⚠ WARNING**

Indicates a potentially hazardous situation which, if not avoided, could result in death or serious injury.

#### **⚠ CAUTION**

Indicates a potentially hazardous situation which, if not avoided, may result in minor or moderate injury and/or property damage. It may also be used to alert against unsafe practices.

## Manual Glossary

**Power Unit** A Ventrac tractor or other Ventrac engine powered device that may be operated by itself or with an attachment or accessory.

**Attachment** A piece of Ventrac equipment that requires a Power Unit for operation.

**Accessory** A device that attaches to a Power Unit or Attachment to extend its capabilities.

**Machine** Describes any "Attachment" or "Accessory" that is used in conjunction with a power unit.

# SAFETY

## Safety Decals

The following safety decals must be maintained on your ED202 edger.

Keep all safety decals legible. Remove all grease, dirt, and debris from safety decals and instructional labels. If any decals are faded, illegible, or missing, contact your dealer promptly for replacements.

When new components are installed, be sure that current safety decals are affixed to the replacement components.

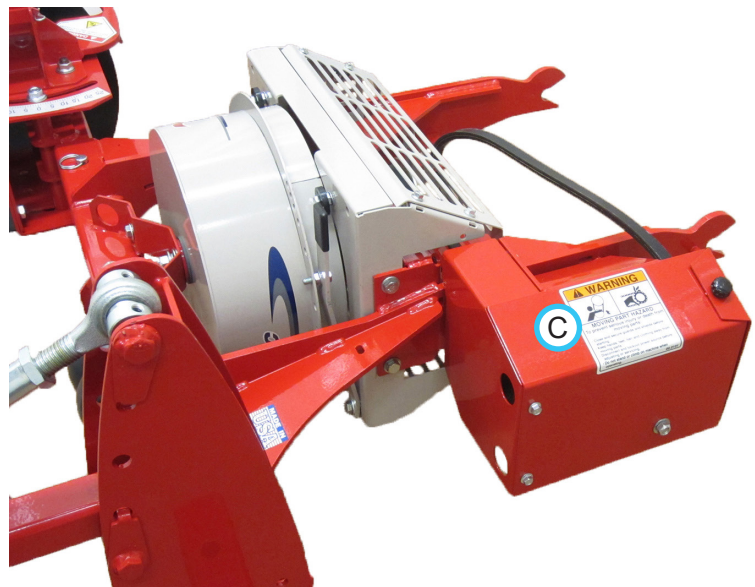

Decal	Description	Part Number	Quantity
A	Danger, Keep Hands & Feet Clear	00.0123	2
B	Warning, Read Owner's Manual	00.0217	1
C	Warning, Moving Part Hazard (optional blower)	00.0101	1

# SAFETY



## General Safety Procedures for Ventrac Power Units, Attachments, & Accessories



### Training Required

- The owner of this machine is solely responsible for properly training the operators.
- The owner/operator is solely responsible for the operation of this machine and prevention of accidents or injuries occurring to him/herself, other people, or property.
- Do not allow operation or service by children or untrained personnel. Local regulations may restrict the age of the operator.
- Before operating this machine, read the operator's manual and understand its contents.
- If the operator of the machine cannot understand this manual, then it is the responsibility of this machine's owner to fully explain the material within this manual to the operator.
- Learn and understand the use of all controls.
- Know how to stop the power unit and all attachments quickly in the event of an emergency.



### Personal Protective Equipment Requirements

It is the responsibility of the owner to be sure that the operators use the proper personal protective equipment while operating the machine. Required personal protective equipment includes, but is not limited to, the following list.



- Wear a certified ear protection device to prevent loss of hearing.
- Prevent eye injury by wearing safety glasses while operating the machine.
- Closed toe shoes must be worn at all times.
- Long pants must be worn at all times.
- When operating in dusty conditions, it is recommended that a dust mask be worn.

### Operation Safety

- Inspect machine before operation. Repair or replace any damaged, worn, or missing parts. Be sure guards and shields are in proper working condition and are secured in place. Make all necessary adjustments before operating machine.
- Some pictures in this manual may show shields or covers opened or removed in order to clearly illustrate any instructions. Under no circumstance should the machine be operated without these devices in place.
- Alterations or modifications to this machine can reduce safety and could cause damage to the machine. Do not alter safety devices or operate with shields or covers removed.
- Before each use, verify that all controls function properly and inspect all safety devices. Do not operate if controls or safety devices are not in proper working condition.
- Check parking brake function before operating. Repair or adjust parking brake if necessary.
- Observe and follow all safety decals.
- All controls are to be operated from the operator's station only.
- Always wear a seat belt if the machine has a roll cage/bar installed and in upright position.
- Ensure the attachment or accessory is locked or fastened securely to the power unit before operating.
- Ensure that all bystanders are clear of the power unit and attachment before operating. Stop machine if someone enters your work area.
- Always be alert to what is happening around you, but do not lose focus on the task you are performing. Always look in the direction the machine is moving.
- Look behind and down before backing up to be sure of a clear path.
- If you hit an object, stop and inspect the machine. Make all necessary repairs before operating machine again.
- Stop operation immediately at any sign of equipment failure. An unusual noise can be a warning of equipment failure or a sign that maintenance is required. Make all necessary repairs before operating machine again.

# SAFETY



## General Safety Procedures for Ventrac Power Units, Attachments, & Accessories



### Operation Safety (continued)

- If equipped with a high/low range feature, never shift between high and low range while on a slope. Always move the machine to level ground and engage the parking brake before shifting range.
- Do not leave machine unattended while it is running.
- Always park the machine on level ground.
- Always shut off engine when connecting attachment drive belt to the power unit.
- Never leave the operator's station without lowering the attachment to the ground, setting the parking brake, shutting off the engine, and removing the ignition key. Make sure all moving parts have come to a complete stop before dismounting.
- Never leave equipment unattended without lowering the attachment to the ground, setting the parking brake, shutting off the engine, and removing the ignition key.
- Only operate in well-lit conditions.
- Do not operate when there is a risk of lightning.
- Never direct the discharge of any attachment in the direction of people, buildings, animals, vehicles, or other objects of value.
- Never discharge material against a wall or obstruction. Material may ricochet back towards the operator.
- Use extra caution when approaching blind corners, shrubs, trees, or other objects that may obscure vision.
- Do not run the engine in a building without adequate ventilation.
- Do not touch the engine or the muffler while the engine is running or immediately after stopping the engine. These areas may be hot enough to cause a burn.
- Do not change the engine governor settings or over-speed the engine. Operating engine at excessive speed may increase the hazard of personal injury.
- To reduce the hazard of fire, keep the battery compartment, engine, and muffler areas free of grass, leaves, excessive grease, and other flammable materials.

### Preventing Accidents



- Clear working area of objects that might be hit or thrown from machine.
- Keep people and pets out of working area.
- Know the work area well before operation. Do not operate where traction or stability is questionable.
- Reduce speed when you are operating over rough ground.
- Equipment can cause serious injury and/or death when improperly used. Before operating, know and understand the operation and safety of the power unit and the attachment being used.
- Do not operate machine if you are not in good physical and mental health, if you will be distracted by personal devices, or are under the influence of any substance which might impair decision, dexterity, or judgment.
- Children are attracted to machine activity. Be aware of children and do not allow them in the working area. Turn off the machine if a child enters the work area.

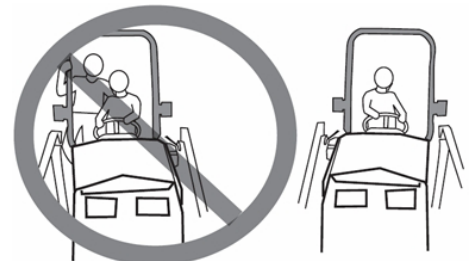

### Keep Riders Off

- Only allow the operator on the power unit. Keep riders off.
- Never allow riders on any attachment or accessory.

# SAFETY



## General Safety Procedures for Ventrac Power Units, Attachments, & Accessories



### Operating On Slopes

- Slopes can cause loss-of-control and tip-over accidents, which can result in severe injury or death. Be familiar with the emergency parking brake, along with the power unit controls and their functions.
- If power unit is equipped with a fold down roll bar, it must be locked in the upright position when operating on any slope.
- Use low range (if equipped) when operating on slopes greater than 15 degrees.
- Do not stop or start suddenly when operating on slopes.
- Never shift between high and low range while on a slope. Always move the power unit to level ground and engage the parking brake before shifting range or placing the power unit in neutral.
- Variables such as wet surface and loose ground will reduce the degree of safety. Do not drive where machine could lose traction or tip over.
- Keep alert for hidden hazards in the terrain.
- Stay away from drop-offs, ditches, and embankments.
- Sharp turns should be avoided when operating on slopes.
- Pulling loads on hills decreases safety. It is the responsibility of the owner/operator to determine loads that can safely be controlled on slopes.
- Transport machine with attachment lowered or close to the ground to improve stability.
- While operating on slopes, drive in an up and down direction when possible. If turning is necessary while driving across slopes, reduce speed and turn slowly in the downhill direction.
- Assure a sufficient supply of fuel for continuous operation. A minimum of one-half tank of fuel is recommended.

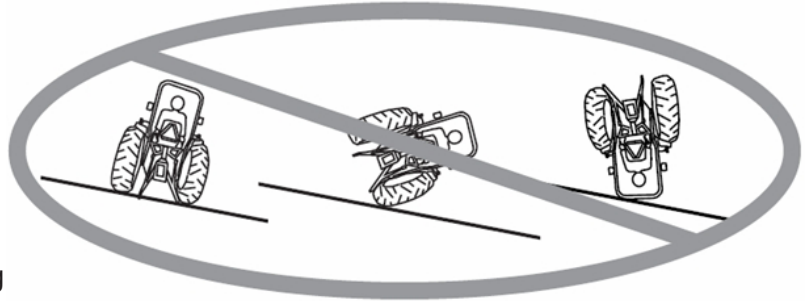

### Roadway Safety

- Operate with safety lights when operating on or near roadways.
- Obey all state and local laws concerning operation on roadways.
- Slow down and be careful of traffic when operating near or crossing roadways. Stop before crossing roads or sidewalks. Use care when approaching areas or objects that may obscure vision.
- If there is doubt of safety conditions, discontinue machine operation until a time when operation can be performed safely.
- When operating near or on roadways, have a Slow Moving Vehicle Emblem clearly displayed.

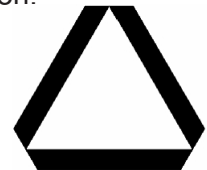

### Truck Or Trailer Transport

- Use care when loading or unloading machine into a truck or trailer.
- Use full width ramps for loading machine into a truck or trailer.
- The parking brake is not sufficient to lock the machine during transport. Always secure the power unit and/or attachment to the transporting vehicle securely using straps, chains, cable, or ropes. Both front and rear straps should be directed down and outward from the machine.
- Shut off fuel supply to power unit during transport on truck or trailer.
- If equipped, turn the battery disconnect switch to the Off position to shut off electrical power.

# SAFETY



## General Safety Procedures for Ventrac Power Units, Attachments, & Accessories



### Maintenance

- Keep all safety decals legible. Remove all grease dirt, and debris from safety decals and instructional labels.
- If any decals are faded, illegible, or missing, contact your dealer promptly for replacements.
- When new components are installed, be sure that current safety decals are affixed to the replacement components.
- If any component requires replacement, use only original Ventrac replacement parts.
- Always turn the battery disconnect to the Off position or disconnect the battery before performing any repairs. Disconnect the negative terminal first and the positive terminal last. Reconnect the positive terminal first and the negative terminal last.
- Keep all bolts, nuts, screws, and other fasteners properly tightened.
- Always lower the attachment to the ground, engage parking brake, shut off engine, and remove the ignition key. Make sure all moving parts have come to a complete stop before cleaning, inspection, adjusting or repairing.
- If the power unit, attachment, or accessory requires repairs or adjustments not instructed in the operator's manual, the power unit, attachment, or accessory must be taken to an authorized Ventrac dealer for service.
- Never perform maintenance on the power unit and/or attachment if someone is in the operator's station.
- Always use protective glasses when handling the battery.
- Check all fuel lines for tightness and wear on a regular basis. Tighten or repair them as needed.
- To reduce the hazard of fire, keep the battery compartment, engine, and muffler areas free of grass, leaves, and excessive grease.
- Do not touch the engine, the muffler, or other exhaust components while the engine is running or immediately after stopping the engine. These areas may be hot enough to cause a burn.
- Allow the engine to cool before storing and do not store near an open flame.
- Do not change the engine governor settings or over-speed the engine. Operating engine at excessive speed may increase the hazard of personal injury.
- Springs may contain stored energy. Use caution when disengaging or removing springs and/or spring loaded components.
- An obstruction or blockage in a drive system or moving/rotating parts may cause a buildup of stored energy. When the obstruction or blockage is removed, the drive system or moving/rotating parts may move suddenly. Do not attempt to remove an obstruction or blockage with your hands. Keep hands, feet, and clothing away from all power-driven parts.
- Dispose of all fluids in accordance with local laws.

### Fuel Safety



- To avoid personal injury or property damage, use extreme care in handling gasoline. Gasoline is extremely flammable and the vapors are explosive.
- Do not refuel machine while smoking or at a location near flames or sparks.
- Always refuel the machine outdoors.
- Do not store machine or fuel container indoors where fumes or fuel can reach an open flame, spark, or pilot light.
- Only store fuel in an approved container. Keep out of reach of children.
- Never fill containers inside a vehicle or on a truck or trailer bed with a plastic liner. Always place containers on the ground away from your vehicle before filling.
- Remove machine from the truck or trailer and refuel it on the ground. If this is not possible, refuel the machine using a portable container, rather than from a fuel dispenser nozzle.
- Never remove fuel cap or add fuel with the engine running. Allow engine to cool before refueling.
- Never remove fuel cap while on a slope. Only remove when parked on a level surface.
- Replace all fuel tank and container caps securely.

# SAFETY



## General Safety Procedures for Ventrac Power Units, Attachments, & Accessories



### Fuel Safety (continued)

- Do not overfill fuel tank. Only fill to bottom of fuel neck, do not fill fuel neck full. Overfilling of fuel tank could result in engine flooding, fuel leakage from the tank, and/or damage to the emissions control system.
- If fuel is spilled, do not attempt to start the engine. Move the power unit away from the fuel spill and avoid creating any source of ignition until fuel vapors have dissipated.
- If the fuel tank must be drained, it should be drained outdoors into an approved container.
- Dispose of all fluids in accordance with local laws.
- Check all fuel lines for tightness and wear on a regular basis. Tighten or repair them as needed.
- The fuel system is equipped with a shut-off valve. Shut off the fuel when transporting the machine to and from the job, when parking the machine indoors, or when servicing the fuel system.

### Hydraulic Safety

- Make sure all hydraulic connections are tight and all hydraulic hoses and tubes are in good condition. Repair any leaks and replace any damaged or deteriorated hoses or tubes before starting the machine.
- Hydraulic leaks can occur under high pressure. Hydraulic leaks require special care and attention.
- Use a piece of cardboard and a magnifying glass to locate suspected hydraulic leaks.



- Keep body and hands away from pinhole leaks or nozzles that eject high pressure hydraulic fluid. Hydraulic fluid escaping under high pressure can penetrate the skin causing serious injury, leading to severe complications and/or secondary infections if left untreated. If hydraulic fluid is injected into the skin, seek immediate medical attention no matter how minor the injury appears.

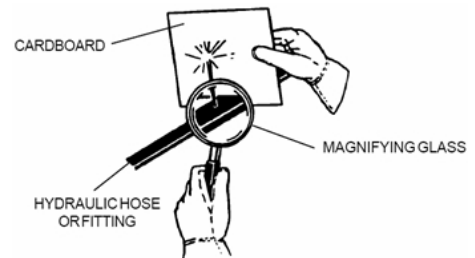

- Hydraulic system may contain stored energy. Before performing maintenance or repairs on the hydraulic system, remove attachments, engage parking brake, disengage weight transfer system (if equipped), shut off engine, and remove ignition key. To relieve pressure on the auxiliary hydraulic system, shut off the power unit engine and move the hydraulic control lever left and right before disconnecting the auxiliary hydraulic quick couplers.
- Dispose of all fluids in accordance with local laws.

# SAFETY

---



## ED202 Safety Procedures



- Prior to edging, ensure the work area is clear obstacles, hazards, and personnel.
- Keep hands and feet away from the edger blade and the edging area.
- Do not make sharp turns with the edging disc in the ground.
- If the edger is equipped with optional blower, disengage the PTO whenever you are not edging.
- The disc edge may be sharp. Wear gloves when handling the disc.

# EDGER SETUP & CONFIGURATION

## Edger Configurations

This section of the manual will explain various edger configurations and how to properly set up these configurations.

### **CAUTION**

The disc edge may be sharp. Wear gloves when handling the edger disc.

## Normal Edging Setup (Disc Concave Facing Toward Frame)

For normal edging operation, the disc is mounted with the concave facing in toward the edger frame. This is the standard factory setup of the edger.



For normal edging setup, the disc and disc mounting components must be installed as shown below.

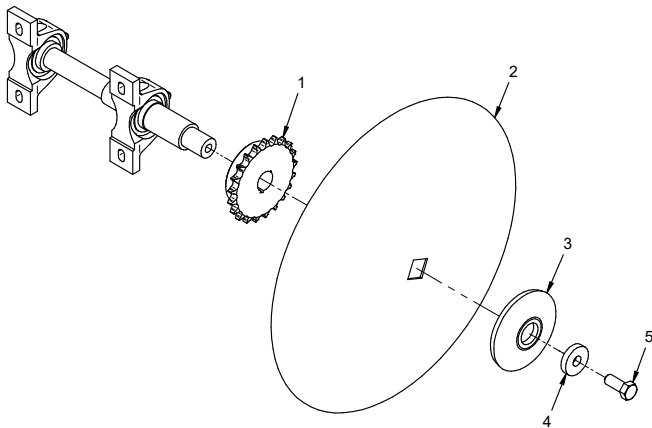

- 1. Disc Sprocket
- 2. Disc
- 3. Disc Washer

- 4. Washer
- 5. Bolt

## Bed Shaping Setup (Disc Concave Facing Away From Frame)

When using the edger for bed shaping, the disc is mounted with the concave facing away from the edger frame. This setup is used for maintaining the edges around flower and mulch beds.



It is recommended when setting up the edger for bed shaping, that the disc assembly is rotated so the disc is on the back side of the main frame receiver tube. To set up edger for bed shaping:

1. Remove the 5/8" bolt (Ref. 5) and the 1-7/8" washer (Ref. 4) from the end of the shaft.
2. Remove the disc washer (Ref. 3), the disc (Ref. 2), and the disc sprocket (Ref. 1) from the shaft.
3. Refer to the Disc Position Setup section for instructions on rotating the disc mount frame to the back side of the main frame receiver tube.
4. Position the disc washer (Ref. 3) and the disc with the concave turned out away from the edger and install onto the shaft.

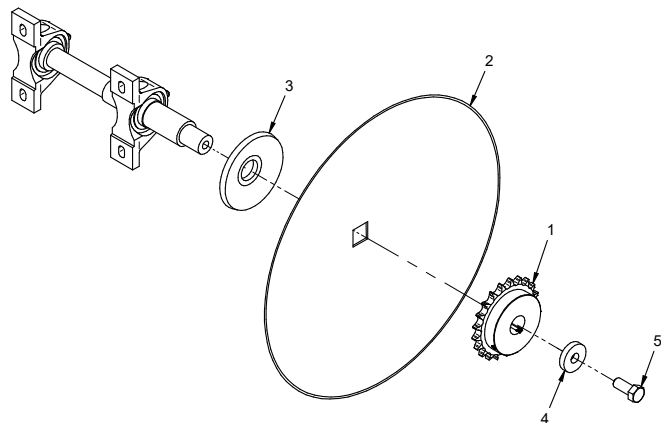

- 1. Disc Sprocket
- 2. Disc
- 3. Disc Washer

- 4. Washer
- 5. Bolt

5. Install the disc sprocket (Ref. 1) onto the shaft and secure with the 1-7/8" washer (Ref. 4) and the 5/8" bolt (Ref. 5).

# EDGER SETUP & CONFIGURATION

- Reinstall the disc guard (A) onto the bearing mount plate using the outer set of holes (B) to position the guard over the edge of the disc.

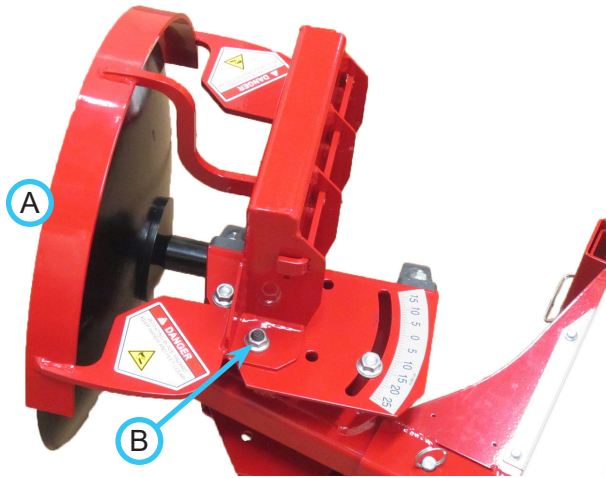

- With the disc positioned on the desired side of the main frame receiver tube, reinsert the disc frame tube into the main frame receiver tube, and secure with the ball pin.

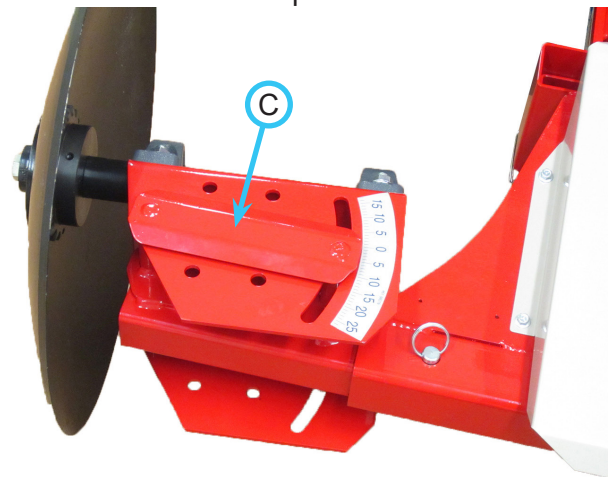

## Disc Position Setup



The edger disc can be positioned either in front of or behind the main frame receiver tube. NOTE: if the edger is equipped with an optional blower kit, positioning the disc behind the main frame receiver tube will block the airflow and prevent debris from being blown away from the edge.

To change the position of the disc:

- Remove the disc guard (A) from the bearing mount frame by removing the 1/2" nuts and washers from the disc guard clamp.
- Remove the ball pin (B) from the frame receiver tube, remove the disc frame assembly from the main frame receiver tube, and rotate the disc frame assembly 180 degrees.

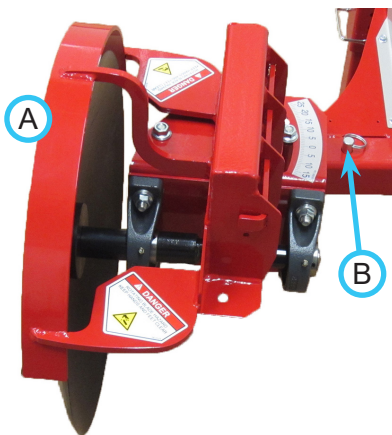

- Remove the disc adjust lock clamp (C) from the top of the bearing mount frame and reinstall the clamp and washers from the bottom and up through the bearing mount frame and disc frame clamp tubes. Secure with the 1/2" flat washers and flange nuts.
- Reinstall the disc guard onto the bearing mount frame in position to cover the top edge of the disc.

## Disc Edger Extension

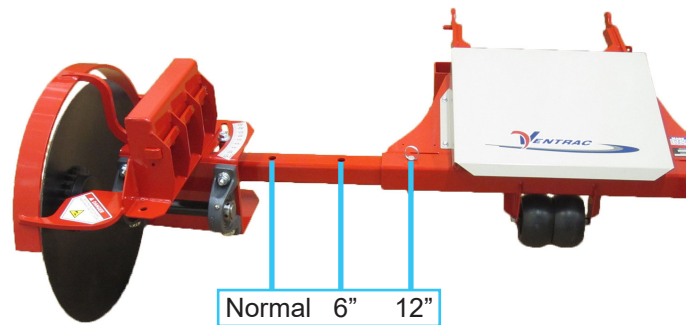

The disc mount frame tube has three mounting positions. The normal mounting position locates the edger disc closest to the main frame. This position should be used whenever possible. The disc frame also can be extended either 6 inches (15.2 cm) or 12 inches (30.5 cm) to reach over curbs or into hard to reach areas.

- Remove the ball pin from the frame receiver tube, slide the disc mount frame tube out to the desired position, and secure with the ball pin.
- After edging of area that requires the edger disc to be extended is complete, return the disc mount frame tube to the normal position.

# EDGER SETUP & CONFIGURATION

---

## Setup For Left Side Operation

The edger can be operated with the disc on the left side of the edger as well as the right. To set up edger for left side operation:

1. Remove the two ball pins (A) from the frame receiver tube and remove both the gauge wheel assembly and the disc frame assembly from the edger.

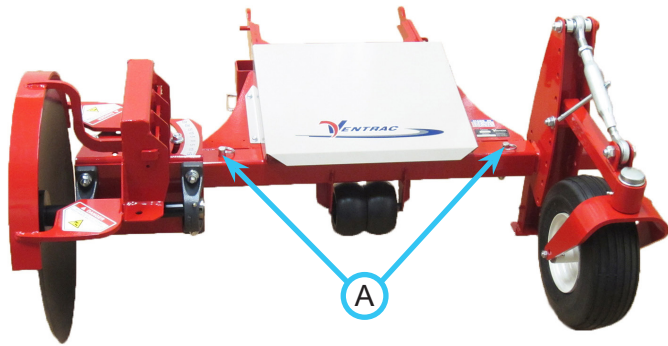

2. Insert the gauge wheel assembly into the right side of the frame receiver tube and secure with the ball pin.
3. Insert the disc frame assembly into the left side of the frame receiver tube and secure with the ball pin.

NOTE: the disc position will be opposite from its previous position on the right side of the edger (i.e. if the disc was positioned in front of the frame receiver tube while mounted on the right side of the edger, it will now be positioned behind the frame receiver tube).



Refer to the Disc Position Setup section for instructions on rotating the disc to the front or rear of the receiver frame tube.

# GENERAL OPERATION

## Daily Inspection

### **⚠ WARNING**

Always set the parking brake, shut off power unit engine, remove the ignition key, and ensure all moving parts have come to a complete stop before inspecting components, or attempting any repair or adjustment.

1. Park machine on a level surface, with the engine shut off and all fluids cold.
2. Perform a visual inspection of both the power unit and the edger. Look for loose or missing hardware, damaged components, or signs of wear.
3. Inspect the drive belts (if equipped). Belts should be in good condition. Service as required.
4. Refer to the power unit operator's manual. Check the power unit's engine oil, hydraulic oil, cooling system, tire pressure, and fuel level. Add fluid or service as required.
5. Test the power unit's operator safety interlock system\*.

## Attaching

1. Drive the power unit slowly forward into the hitch arms of the edger. Align the lift arms of the power unit with the edger hitch arms by raising or lowering the front hitch and complete the engagement.
2. Once completely engaged, close the front hitch locking lever.\*
3. Engage the parking brake\* and shut off the engine.
4. If equipped with the blower option, place the attachment belt onto the PTO drive pulley on the power unit. Ensure the belt is properly seated in each pulley.
5. Engage the power unit's PTO belt tension lever.\*
6. Raise the power unit's front hitch and edger, move the two stands (A) all the way up, and secure with the safety snap pins (B).

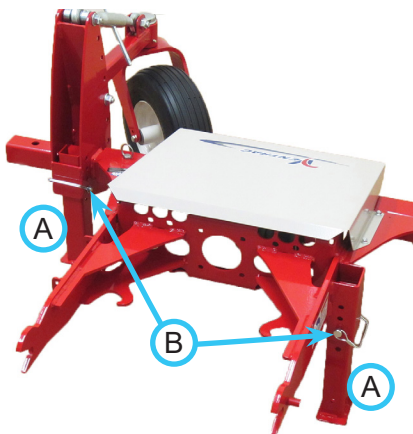

## Detaching

1. Park the power unit on a level surface and set the parking brake.\*
2. Lower the edger to the ground.
3. Shut off power unit engine.
4. If equipped with the blower option, disengage the power unit's PTO belt tension lever\* and remove the attachment belt from the PTO drive pulley of the power unit.
5. Lower the two stands to the ground and secure with the safety snap pins.
6. Disengage the front hitch locking lever.\*
7. Restart power unit and slowly back away from the edger. A side to side movement of the steering wheel may aid in disengagement.

## Operating Procedure

Prior to operation, set the edger disc to the desired angle and set the gauge wheel to the desired cutting depth. Refer to the disc angle and cutting depth adjustment sections for adjustment instructions. If unsure of cutting angle or depth, start with a conservative setting and make adjustments to cutting angle and depth until the desired result is achieved.

For sidewalk edging, start with the front of the edger disc set at 2-3 degrees away from the edger frame and a cutting depth of 1 inch (2.5 cm). Adjust the cutting depth as necessary to cut through the grass roots next to the sidewalk. Adjust the cutting angle in small increments (1-2 degrees) until the desired edge is achieved.



Edging angle

For bed shaping/edging, start with the rear of the edger disc set at 6-8 degrees away from the edger frame and a cutting depth of 3-4 inches (7.5 -10 cm). Adjust the cutting depth as necessary to cut below the root line of the grass. Adjust the cutting angle as necessary to create an air gap between the grass and flower or mulch bed. Maintaining an open gap prevents the grass from growing into the flower or mulch bed. Disengage the power unit's weight transfer system\*. Move the power unit and edger into position and lower the edger slowly into the ground. If the edger is equipped with an optional blower, engage the PTO



Bed shaping angle

\* Refer to power unit operator's manual for operation of power unit controls.

# GENERAL OPERATION

switch to activate the fan. Drive forward slowly while continuing to lower the edger until the tire touches the ground. Move the SDLA lever to the float position and maintain a speed that allows the operator to control the edger. Guide the edger disc along the edge of the sidewalk or other edging area. At the end of the edging line, decrease the power unit speed and lift the edger out of the ground. If equipped with a blower option, shut off the PTO switch.

Do not make sharp turns with the disc in the ground. If the edger will not cut to the desired depth, weight must be added. The weight bar bracket (A) on the disc guard frame will accommodate three Ventrac weights (part # 47.0115).

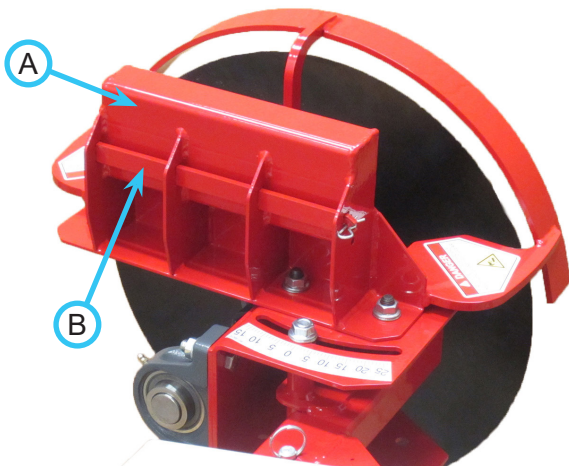

Remove the weight retainer pin and install the weights onto the weight bar. Reinstall the weight retainer pin and secure with the hair pin.

## Edger Disc Angle Adjustment

The disc angle can be changed to create a wider or narrower edging line. To change the disc angle:

1. Loosen the two 1/2" nuts (A) on top of the bearing mount frame.
2. Rotate the edger disc to the desired angle. The decal on the bearing mount frame is useful for setting a desired angle or for measuring small incremental adjustments to the disc angle.
3. Retighten the 1/2" nuts to lock the disc angle.

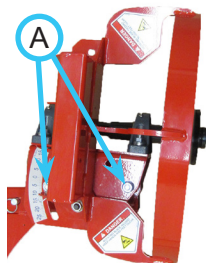

## Edger Cutting Depth Adjustment

1. Park the power unit and edger on a level surface, preferably concrete or asphalt.
2. Lower the edger until the edger disc just touches the surface.

3. Measure the distance between the surface and the bottom of the tire to determine the approximate edging depth.



4. If the cutting depth needs to be adjusted, loosen the locking nut (A) on the adjustable link (B).

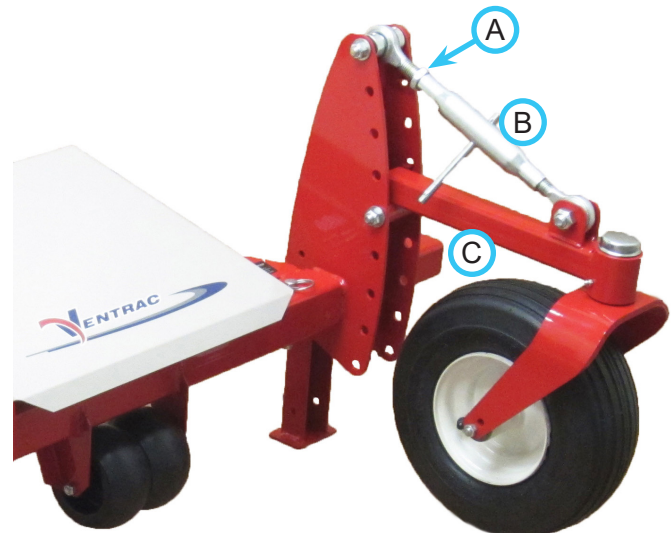

5. Turn the adjustable link until the measurement between the surface and the bottom of the tire reaches the desired depth. For a shallower cut, lengthen the adjusting link. For a deeper cut, shorten the adjusting link.
6. When the desired depth is reached, tighten the locking nut against the body of the adjustment link.

NOTE: the gauge wheel arm (C) should be as near level as possible. Move the gauge wheel arm and the adjusting link up or down in the series of holes in the gauge wheel frame in order to maintain a near level position.

# GENERAL OPERATION

---

## Discharge Direction Adjustment For Optional Blower Fan

The fan housing can be rotated to direct the airflow to either the right or left side of the edger, depending on which side the edger disc is mounted.

1. Push the rotation index arm (A) toward the frame until the bolt disengages from the blower housing.

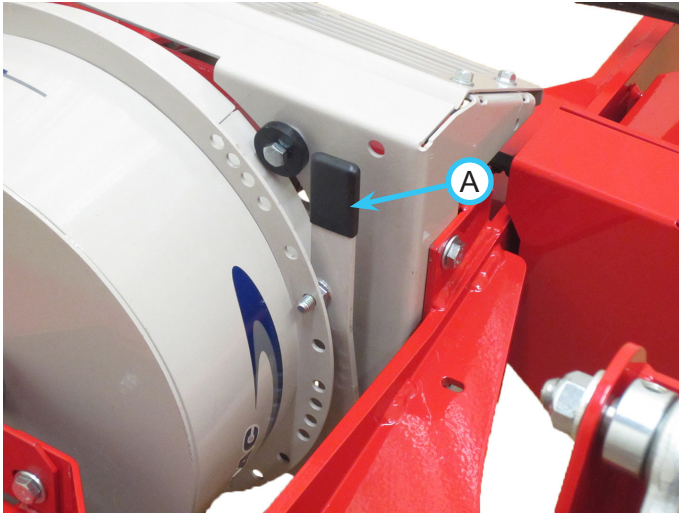

2. Rotate the blower housing until the discharge is pointed in the desired direction.
3. Release the rotation index arm, making sure that the bolt engages in the nearest hole in the blower housing to lock in place.

# SERVICE

## ⚠ WARNING

Always set the parking brake, shut off power unit engine, remove the ignition key, and ensure all moving parts have come to a complete stop before inspecting components or attempting any repair or adjustment.



## Attention

If any component requires replacement, use only original Ventrac replacement parts.

## Cleaning and General Maintenance

For best results, and to maintain the finish of the edger, clean or wash the edger after each use to remove dirt, grass, and debris.

## Tire Pressure

Tire pressure should be maintained between 18-20 psi (124-138 kPa).

## Lubrication Locations

Lubrication is required at the following locations using a lithium complex NLGI #2 grease. Refer to the maintenance schedule for service intervals and amount of grease.

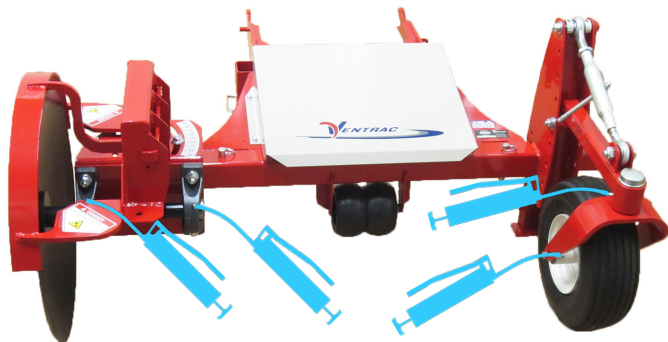

Drive Shaft Bearings  
Optional Blower Kit

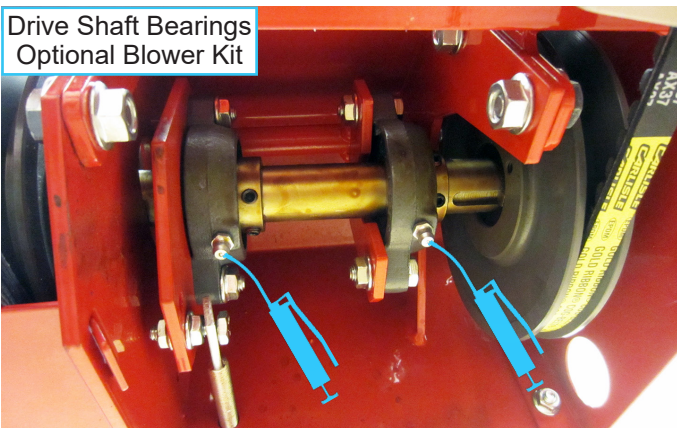

## Belt Inspection (Optional Blower Kit)

Inspecting the drive belts of the edger blower can prevent sudden belt failure by finding problems before they cause a belt to break.

Typical wear on a drive belt may result in the conditions shown in the diagram. If any of these conditions occur, the drive belt will require replacement.



Glazing



Streaked Sidewalls



Cracks



Tensile Break



Separation

## Attachment Drive Belt Replacement

1. Detach the edger from the power unit.
2. Remove the drive pulley shield (A).
3. Remove the old drive belt and install the new drive belt onto the pulley.
4. Reinstall the drive pulley shield.

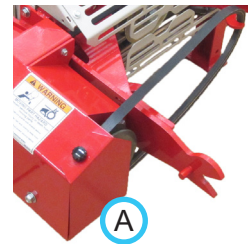

# SERVICE

## Fan Drive Belt Replacement

1. Detach the edger from the power unit.
2. Remove the front drive shaft cover (A) and the top and bottom fan inlet screens (B) from the edger.

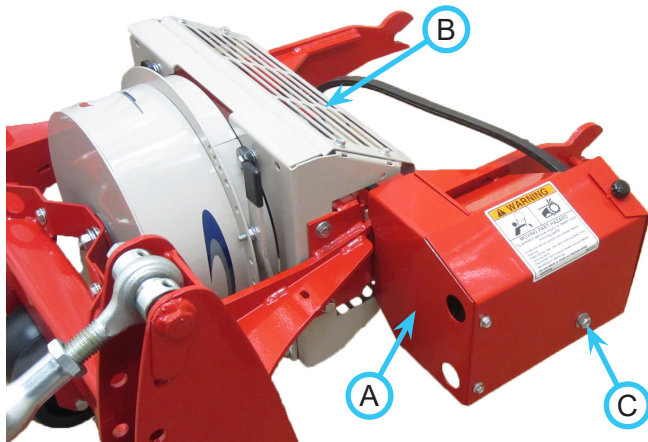

3. Remove the 3/8" lock nut (C) and washer from the belt tensioner bolt.
4. Remove the fan drive belt from the drive shaft pulley first, then remove the belt from the fan spindle pulley.
5. Unfasten the attachment drive belt from the right hitch arm tab.
6. Pull the old fan belt over the drive shaft housing and off the left hitch arm.
7. Install the new drive belt over the left hitch arm and drive shaft housing.
8. Install the belt onto the fan spindle pulley first, then onto the drive shaft pulley.
9. Reinstall the washer and 3/8" lock nut onto the belt tensioner bolt and tighten to apply belt tension.
10. Reinstall the top and bottom fan inlet screens and the front drive shaft cover.

## Storage

### Preparing the Edger for Storage

1. Clean the edger to remove grass, dirt, and debris.
2. Inspect for loose or missing hardware, damaged components, or signs of wear. Repair or replace any damaged or worn components.
3. Inspect safety decals. Replace any decals that are faded, illegible, or missing.
4. Apply grease to all grease points and wipe off any excess grease.
5. If equipped with blower option, inspect belts for signs of damage or wear and replace if necessary.

### Removing the Edger from Storage

1. Clean the edger to remove any accumulated dust or debris.
2. Inspect the edger as instructed in the daily inspection section of this manual.

# SERVICE

## Maintenance Schedule

Maintenance Schedule	# of Locations	# of Pumps	Daily	At 25 Hours	At 50 Hours	At 75 Hours	At 100 Hours	At 125 Hours	At 150 Hours	At 175 Hours	At 200 Hours	At 225 Hours	At 250 Hours	At 275 Hours	At 300 Hours	At 325 Hours	At 350 Hours	At 375 Hours	At 400 Hours	At 425 Hours	At 450 Hours	At 475 Hours	At 500 Hours	Yearly		
																									Grease & Lubrication: See Lubrication Section	
Disc Shaft Bearing	2	1		✓		✓		✓		✓		✓		✓		✓		✓		✓		✓		✓		✓
Caster Wheel Pivot	1	1		✓		✓		✓		✓		✓		✓		✓		✓		✓		✓		✓		✓
Wheel Axle Bearing	1	^		✓		✓		✓		✓		✓		✓		✓		✓		✓		✓		✓		✓
Drive Shaft Bearing (Blower Option)	2	1		✓		✓		✓		✓		✓		✓		✓		✓		✓		✓		✓		✓
Inspection																										
Inspect for Loose, Missing, or Worn Components.			✓																							
Inspect Safety Decals			✓																							
Check Tire Pressure			✓																							
Inspect Drive Belts (Blower Option)			✓																							

^Grease until fresh grease is visible.

## Maintenance Checklist

Maintenance Checklist	# of Locations	# of Pumps	At 25 Hours	At 50 Hours	At 75 Hours	At 100 Hours	At 125 Hours	At 150 Hours	At 175 Hours	At 200 Hours	At 225 Hours	At 250 Hours	At 275 Hours	At 300 Hours	At 325 Hours	At 350 Hours	At 375 Hours	At 400 Hours	At 425 Hours	At 450 Hours	At 475 Hours	At 500 Hours	Yearly			
																								Grease & Lubrication: See Lubrication Section		
Disc Shaft Bearing	2	1																								
Caster Wheel Pivot	1	1																								
Wheel Axle Bearing	1	^																								
Drive Shaft Bearing (Blower Option)	2	1																								
Inspection																										
Inspect for Loose, Missing, or Worn Components.																										
Inspect Safety Decals																										
Check Tire Pressure																										
Inspect Drive Belts (Blower Option)																										

^Grease until fresh grease is visible.

# SPECIFICATIONS

---

## Dimensions

Overall Height . . . . .	21 inches (53 cm)
Overall Length . . . . .	45 inches (114 cm)
Overall Width . . . . .	54 - 66 inches (137 - 168 cm)
Weight . . . . .	200 pounds (90 kg)
Weight with Blower Option. . . . .	230 pounds (104 kg)
Disc Diameter . . . . .	20 inches (51 cm)
Maximum Cutting Depth . . . . .	6 inches (15 cm)

## Features

- Reversible cutting disc for both edging or bed shaping
- Right or left side edging capability
- 3 position extendable disc arm
- Weight bar
- Optional debris blower

# PARTS

## ILLUSTRATED DRAWING Main Frame

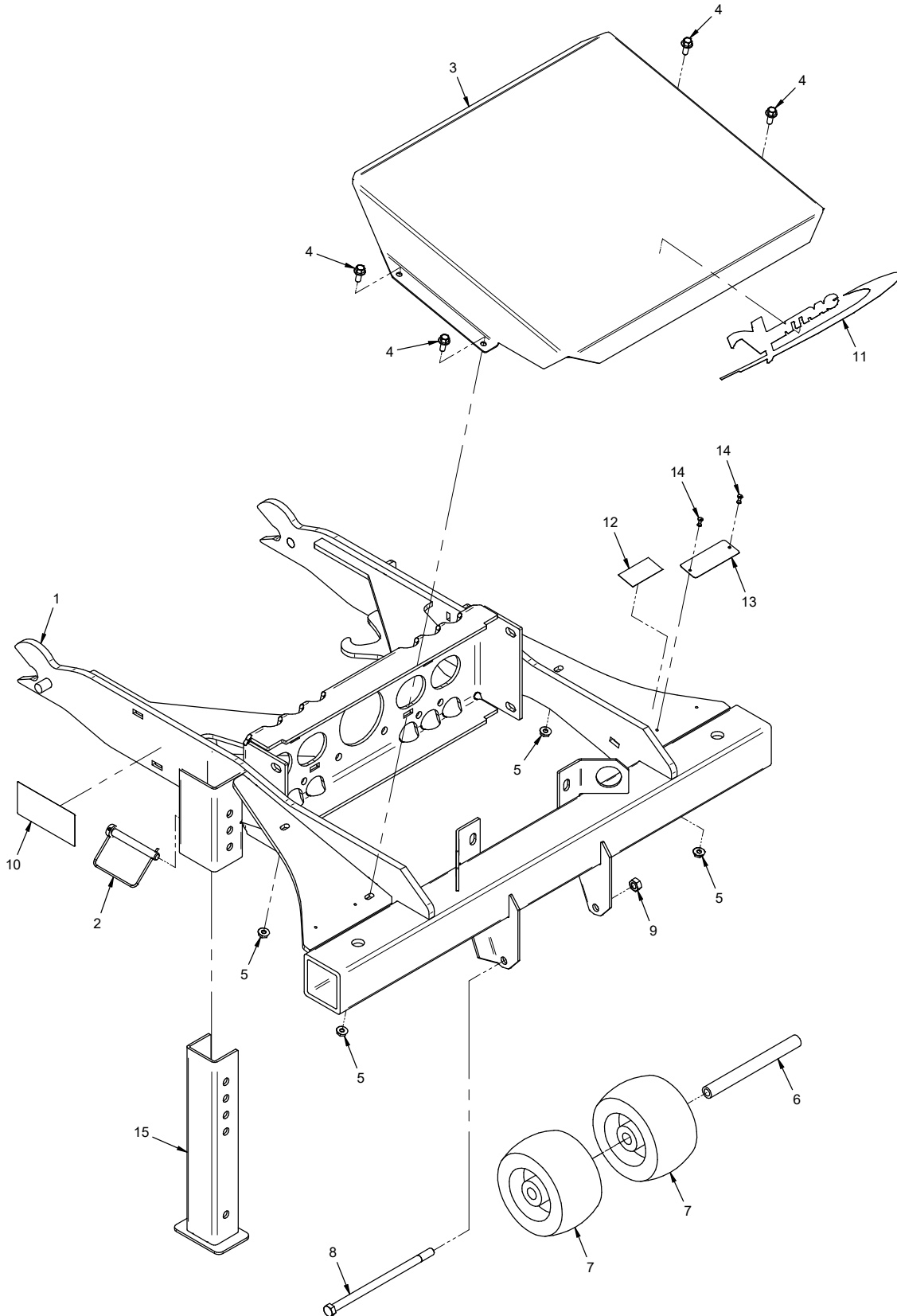

# PARTS

## Main Frame

REF.	PART NO.	DESCRIPTION	QTY.
1	62.1466	.FRAME, MAIN ED202	1
2	03.0015	.PIN, SAFETY SNAP 3/8 X 3"	1
3	60.0861	.SHIELD, MAIN COVER	1
4	99.SF0405-1	.BOLT, SMF 1/4-20 X 5/8	4
5	99.SF04	.NUT, SRF 1/4-20 USS	4
6	50.0170	.TUBE, RD .385 X 5/8 X 6-1/4L	1
7	50.0060	.ROLLER, 5 X 2.75 X 5/8 BORE	2
8	90.0656	.BOLT, HEX 3/8-16 UNC X 7	1
9	99.A06	.LOCKNUT, STOVER 3/8-16 USS	1
10	00.0217	.DECAL, WARNING READ OWNERS MAN	1
11	00.0189	.DECAL, VENTRAC ORBITAL	1
12	00.0100	.DECAL, MADE IN USA	1
13	N/A	.PLATE, VENTRAC SERIAL NUMBER	1
14	04.0032	.RIVET, POP 1/8 X 1/2	2
15	62.1027	.STAND, JACK EA600	1

# PARTS

## ILLUSTRATED DRAWING Gauge Wheel

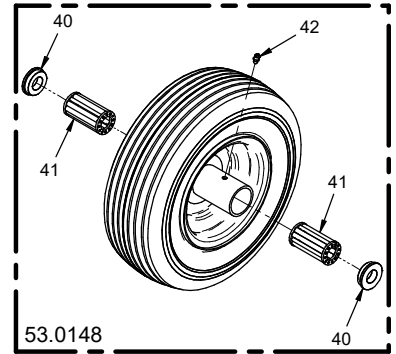
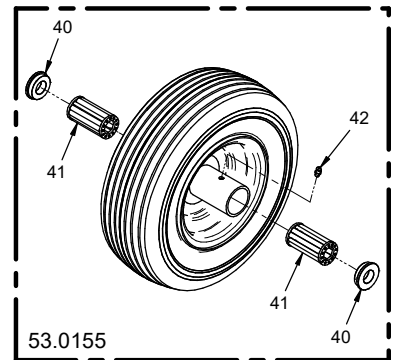
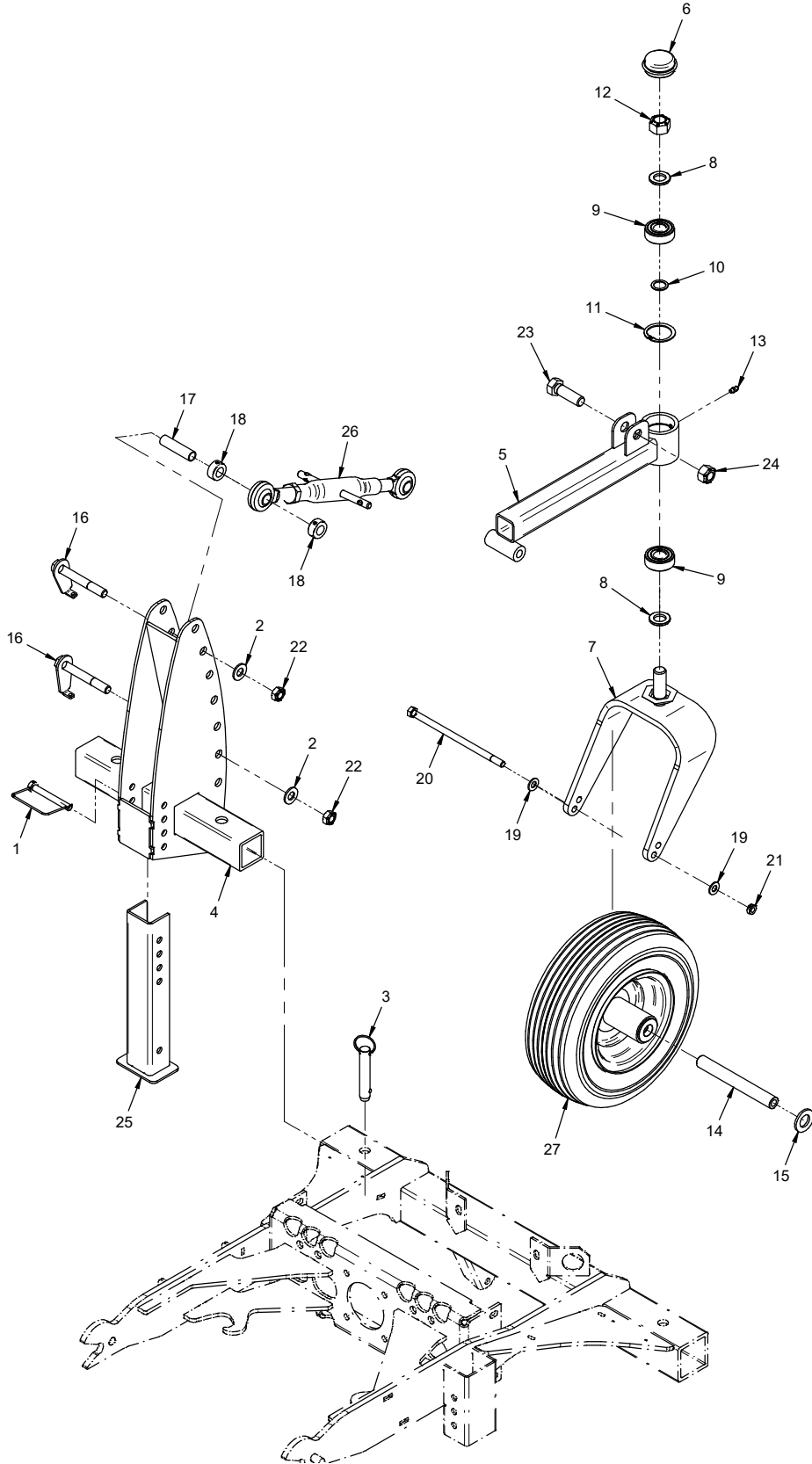

# PARTS

## Gauge Wheel

REF.	PART NO.	DESCRIPTION	QTY.
1	03.0015	.PIN, SAFETY SNAP 3/8 X 3"	1
2	95.08	.WASHER, FLAT 1/2 SAE	2
3	03.0013	.PIN, BALL, 5/8 X 2-1/2	1
4	62.1467	.FRAME, GAUGE WHEEL MOUNT	1
5	62.0972	.TUBE, CASTER WHEEL MOUNT	1
6	53.0080	.DUST CAP, BEARING MOWER CASTER	1
7	50.0183	.YOKE, CASTER 13", HIGH/LOW	1
8	99.B0057	.WASHER, MACH 3/4 X 1-1/4 10 GA	2
9	55.0023	.BEARING, BALL .75 ID X 1.78 OD	2
10	99.B0052	.SHIM, STEEL 3/4 X 1 X .062	1
11	04.0013	.SNAP RING, INT .062 X 1.75	1
12	99.A12NF	.LOCKNUT, STOVER 3/4-16 SAE	1
13	29.GF0001	.GREASE FTG, 1/4 SAE ST	1
14	50.0050	.TUBE, SWIVEL AXLE	1
15	95.12	.WASHER, FLAT 3/4 SAE	1
16	64.1072	.BOLT, WHEEL ADJUST ANCHOR	2
17	50.0171	.TUBE, RD .527 X 5/8 X 2-13/32L	1
18	85.SC11	.SET COLLAR, 11/16	2
19	95.06	.WASHER, FLAT 3/8 SAE	2
20	90.0660	.BOLT, 3/8-16 USS X 7-1/2	1
21	99.A06C	.LOCKNUT, CENTER 3/8-16	1
22	99.A08	.LOCKNUT, STOVER 1/2-13 USS	2
23	90.1016	.BOLT, 5/8-11 UNC X 2	1
24	99.A10	.LOCKNUT, STOVER 5/8-11 USS	1
25	62.1027	.STAND, JACK EA600	1
26	47.0222	.TOP LINK, CAT. #0, ADJUSTABLE	1
27	53.0155	.WHEEL, ASM 13 X 5 X 6 CASTER	1
27	53.0148	.WHEEL, ASM 13x5x6 RIB FLATFREE (Optional)	1
40	55.0072	.BEARING, RETAINER 3/4"	2
41	55.0088	.BEARING, ROLLER REPLACEMENT	2
42	29.GF0001	.GREASE FTG, 1/4 SAE ST	1

# PARTS

## ILLUSTRATED DRAWING Disc Mount Frame

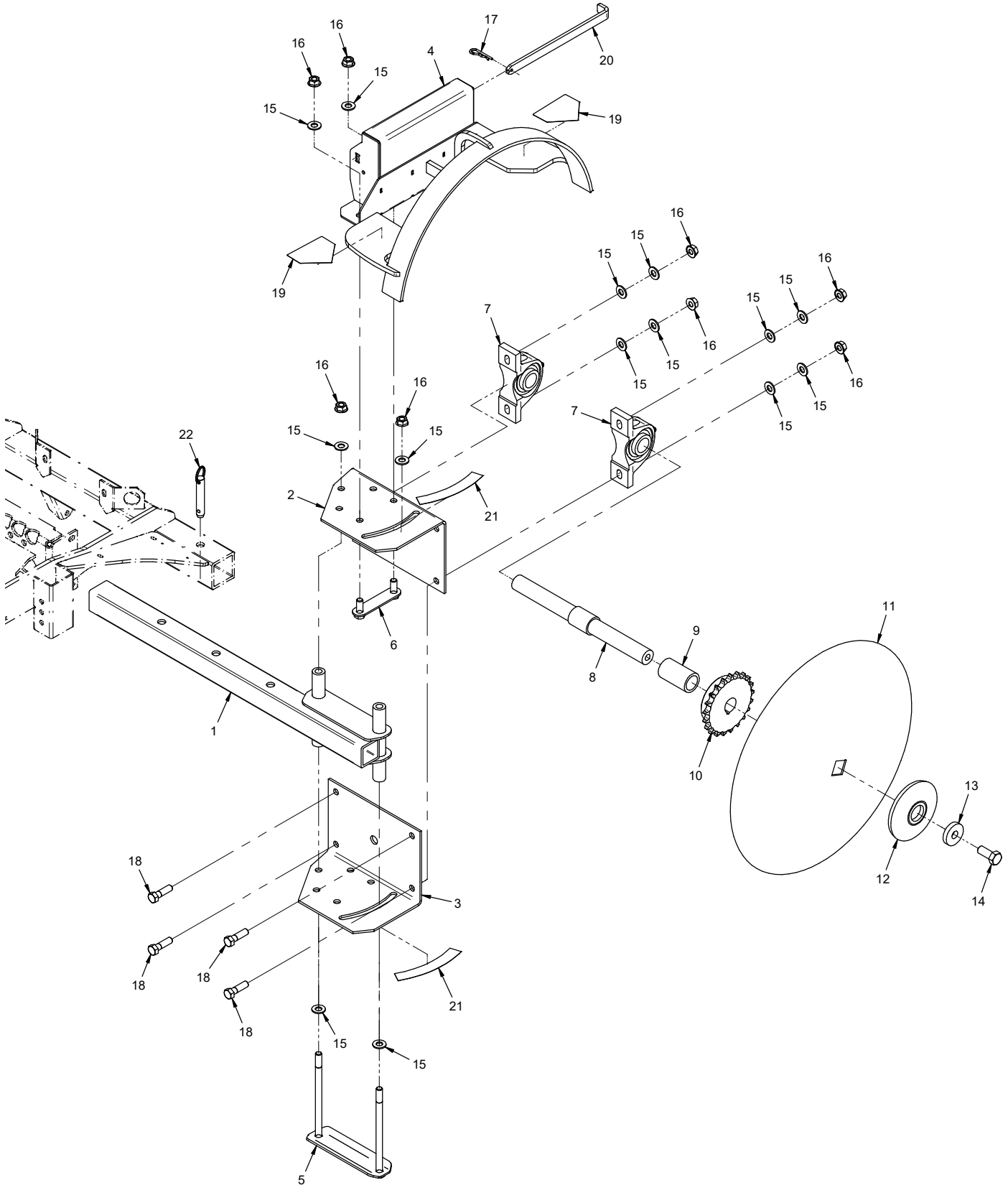

# PARTS

## Disc Mount Frame

REF.	PART NO.	DESCRIPTION	QTY.
1	62.0971	.FRAME, DISC MOUNT TUBE	1
2	62.1487	.FRAME, DISC BEARING MT UPPER	1
3	62.1488	.FRAME, DISC BEARING MT LOWER	1
4	62.1468	.FRAME, WEIGHT BAR/DISC GUARD	1
5	64.1070	.CLAMP, DISC ADJUSTER LOCK	1
6	64.1071	.CLAMP, DISC GUARD	1
7	55.PB25020	.BEARING, PILLOW BLOCK, 1-1/4	2
8	80.0342	.SHAFT, DISC MOUNT	1
9	64.1069	.PIPE, SCH 40 1-1/4 X 2-7/8	1
10	83.H602120	.SPROCKET, #60 21T, 1-1/4 BORE	1
11	79.0066	.DISC, 20" 1-1/4 SQ HOLE	1
12	64.1067	.WASHER, 3/8 X 1.375 X 5	1
13	99.B0081	.WASHER, 3/8 X .656 X 1.875	1
14	90.1012	.BOLT, HEX 5/8-11 UNC X 1-1/2	1
15	95.08	.WASHER, FLAT 1/2 SAE	14
16	99.SF08	.NUT, SRF 1/2-13 USS	8
17	02.HP0416	.HAIRPIN, 1/8 X 2	1
18	90.0814	.BOLT, 1/2-13 USS X 1-3/4	4
19	00.0123	.DECAL, KEEP HANDS & FEET CLEAR	2
20	64.1312	.PIN, WEIGHT RETAINER	1
21	00.0429	.DECAL, EDGER ANGLE INDICATOR	1
22	03.0013	.PIN, BALL, 5/8 X 2-1/2	1

# PARTS

## ILLUSTRATED DRAWING Optional Blower Frame & Inlet Screens

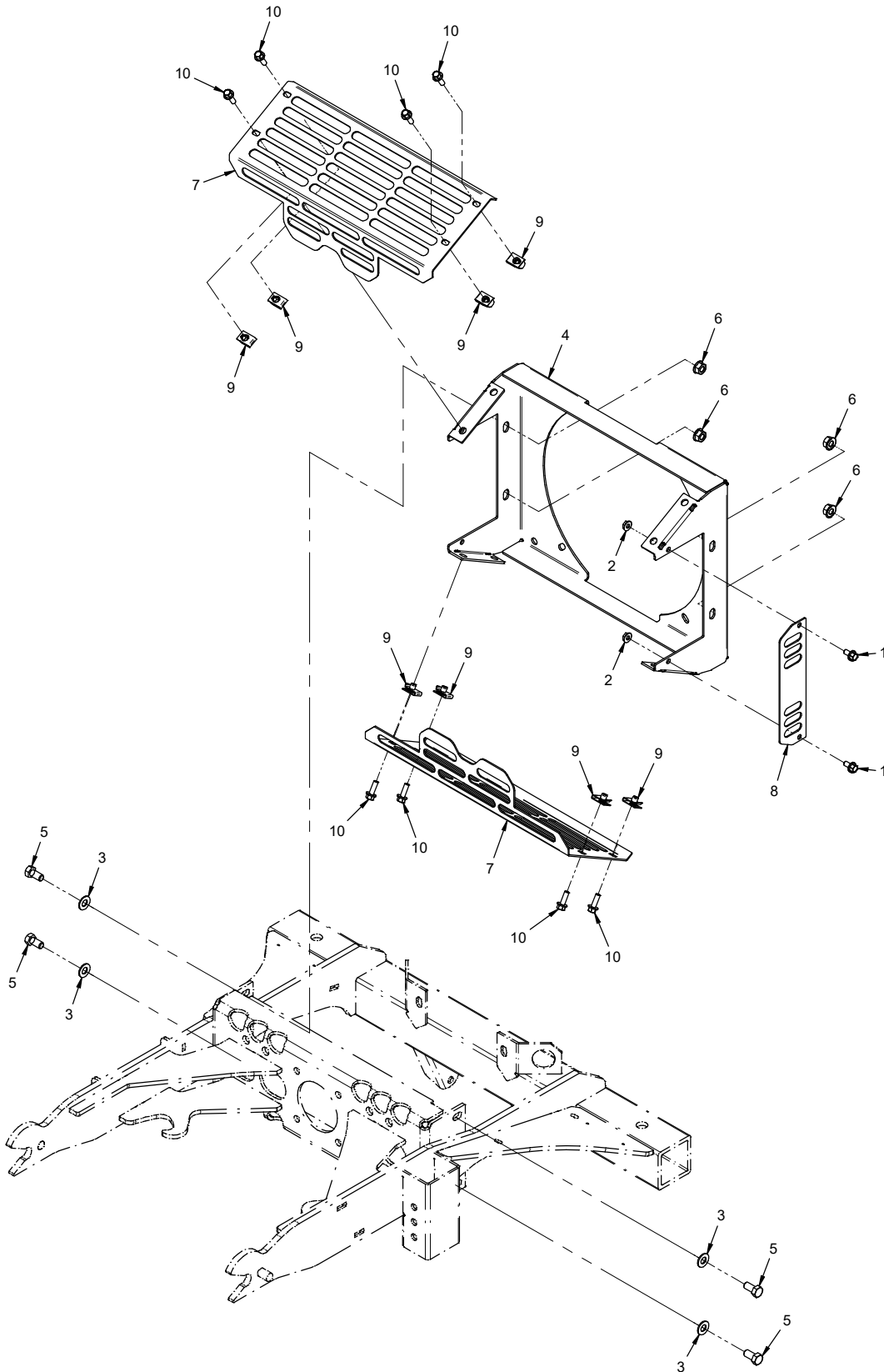

# PARTS

## Optional Blower Frame & Inlet Screens

REF.	PART NO.	DESCRIPTION	QTY.
1	99.SF0404-1	.BOLT, SMF 1/4-20 X 1/2	2
2	99.SF04	.NUT, SRF 1/4-20 USS.	2
3	95.06	.WASHER, FLAT 3/8 SAE	4
4	62.0974	.FRAME, AIR INLET	1
5	90.0606	.BOLT, HEX 3/8-16 UNC X 3/4.	4
6	99.SF06	.NUT, SRF 3/8-16 USS.	4
7	60.0863	.SCREEN, FAN INLET.	2
8	60.0864	.SHIELD, RIGHT SIDE INTAKE	1
9	99.E0046	.NUT, "U" 1/4-20 EXTRUDED	8
10	99.SF0406-1	.BOLT, SMF 1/4-20 X 3/4	8

# PARTS

## ILLUSTRATED DRAWING Optional Blower Housing

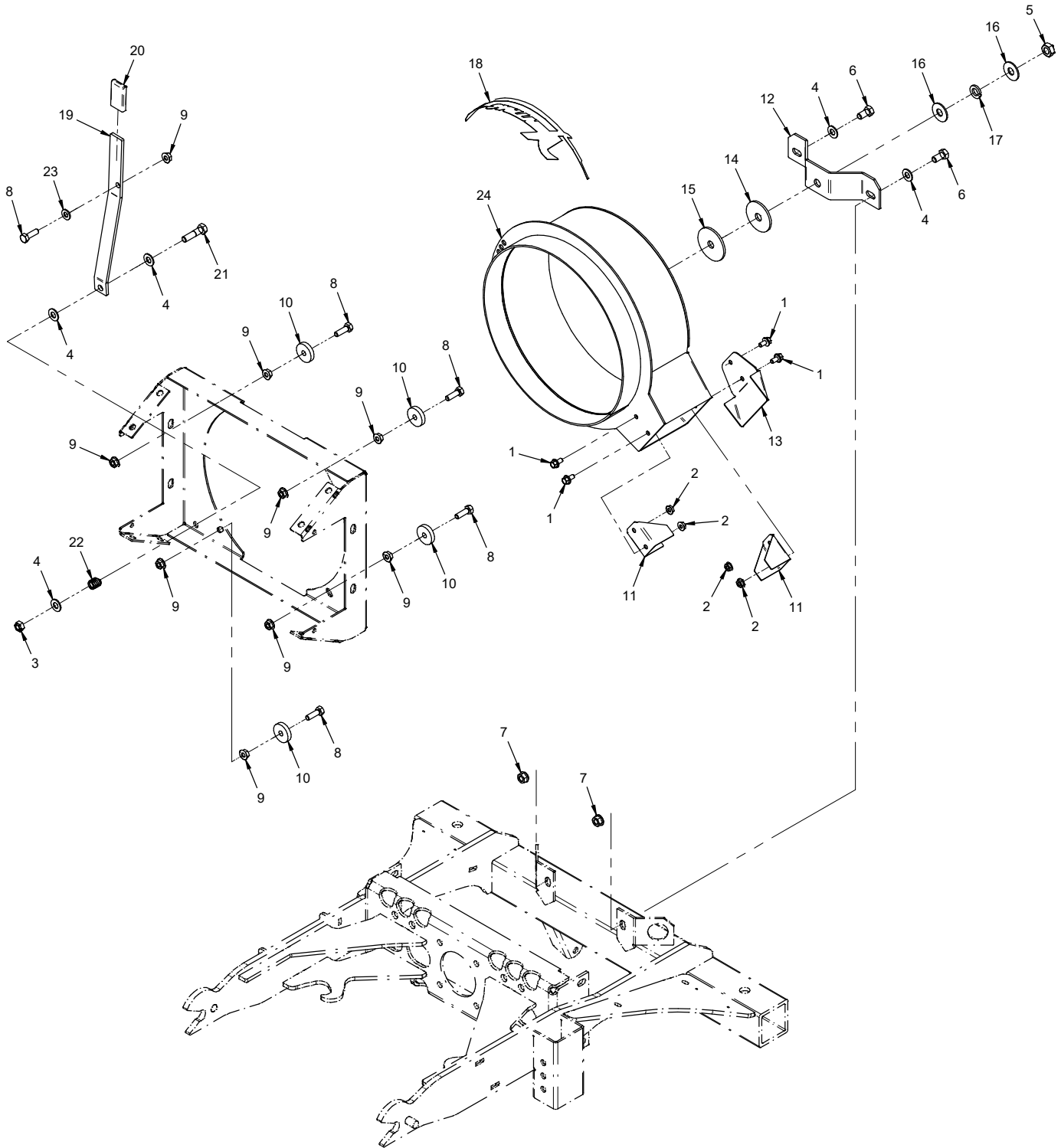

# PARTS

## Optional Blower Housing

REF.	PART NO.	DESCRIPTION	QTY.
1	99.SF0404-1	.BOLT, SMF 1/4-20 X 1/2	4
2	99.SF04	.NUT, SRF 1/4-20 USS	4
3	99.A06	.LOCKNUT, STOVER 3/8-16 USS	1
4	95.06	.WASHER, FLAT 3/8 SAE	5
5	99.A08	.LOCKNUT, STOVER 1/2-13 USS	1
6	90.0606	.BOLT, HEX 3/8-16 UNC X 3/4	2
7	99.SF06	.NUT, SRF 3/8-16 USS	2
8	90.0508	.BOLT, HEX 5/16-18 UNC X 1"	5
9	99.SF05	.NUT, SRF 5/16-18 USS	9
10	05.0069	.WASHER, NYLON	4
11	64.1073	.GUARD, FAN OUTLET	2
12	64.1075	.BRACKET, FRONT BLOWER MT	1
13	64.1199	.BRACKET, AIR DEFLECTOR	1
14	99.B0080	.WASHER, 17/32 X 2-1/16 10GA	1
15	05.0098	.WASHER, 1/2ID X 2-1/4OD 1/8THK	1
16	94.07	.WASHER, FLAT 7/16 USS	2
17	96.08	.WASHER, LOCK 1/2	1
18	00.0189	.DECAL, VENTRAC ORBITAL	1
19	64.1074	.ARM, ROTATION INDEX	1
20	06.0051	.CAP, 3/16 X 15/16 X 1-3/4 FE	1
21	90.0612	.BOLT, HEX 3/8-16 UNC X 1-1/2	1
22	41.0039	.SPRING, COMP. 9/16 OD X 5/8	1
23	95.05	.WASHER, FLAT 5/16 SAE	1
24	62.0975	.HOUSING, BLOWER	1

# PARTS

## ILLUSTRATED DRAWING Optional Blower Drive Frame & Shields

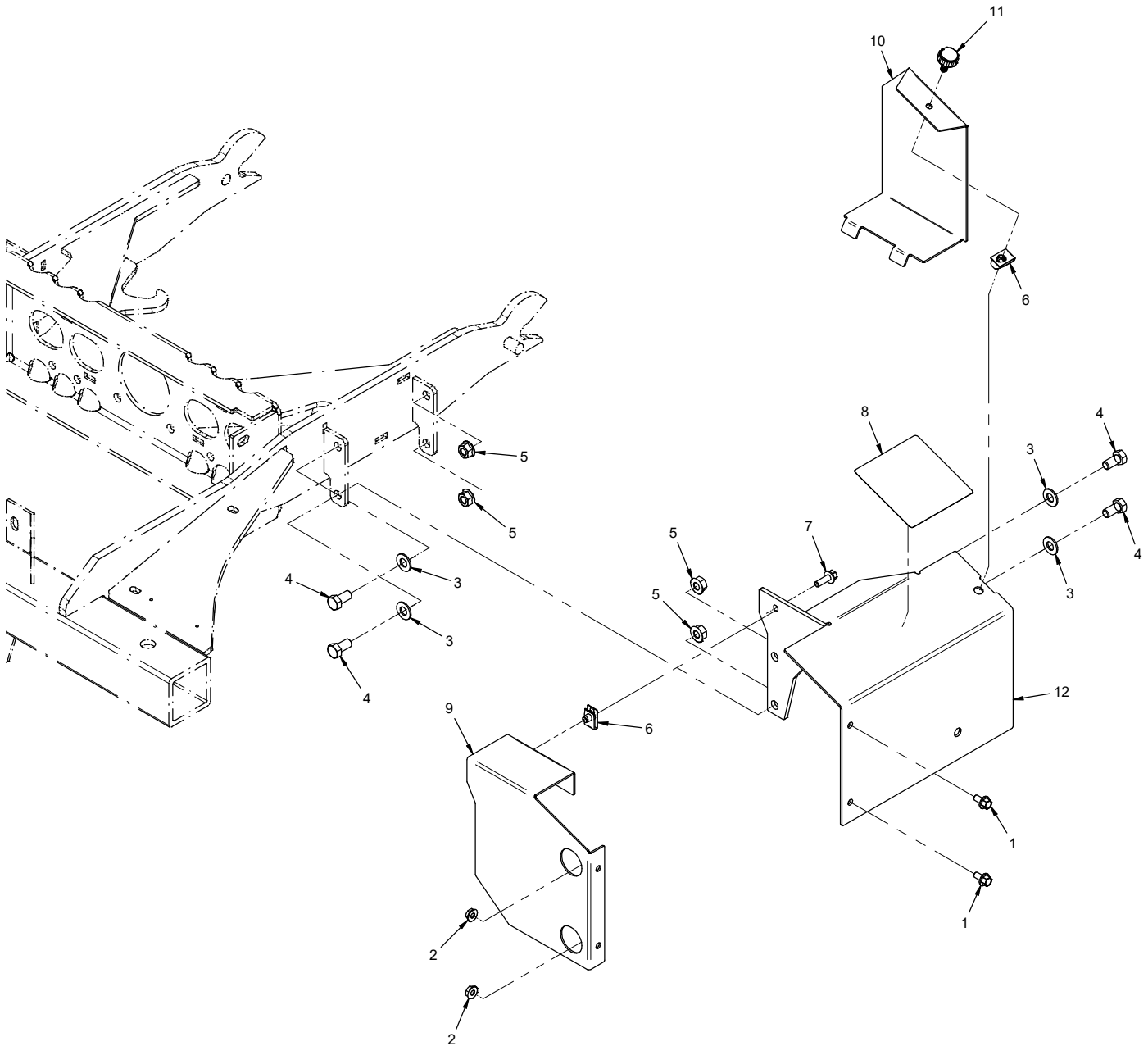

# PARTS

## Optional Blower Drive Frame & Shields

REF.	PART NO.	DESCRIPTION	QTY.
1	99.SF0404-1	.BOLT, SMF 1/4-20 X 1/2	2
2	99.SF04	.NUT, SRF 1/4-20 USS.	2
3	95.06	.WASHER, FLAT 3/8 SAE	4
4	90.0606	.BOLT, HEX 3/8-16 UNC X 3/4.	4
5	99.SF06	.NUT, SRF 3/8-16 USS.	4
6	99.E0046	.NUT, "U" 1/4-20 EXTRUDED	2
7	99.SF0406-1	.BOLT, SMF 1/4-20 X 3/4	1
8	00.0101	.DECAL, HAZARD-MOVING PART	1
9	60.0862	.SHIELD, FRONT J-SHAFT HOUSING	1
10	60.0865	.SHIELD, DRIVE PULLEY	1
11	47.0167	.KNOB, 1/4-20 X 1-1/4 DIA BLACK	1
12	62.0976	.FRAME, J-SHAFT HOUSING	1

# PARTS

## ILLUSTRATED DRAWING Optional Blower Drive Shaft

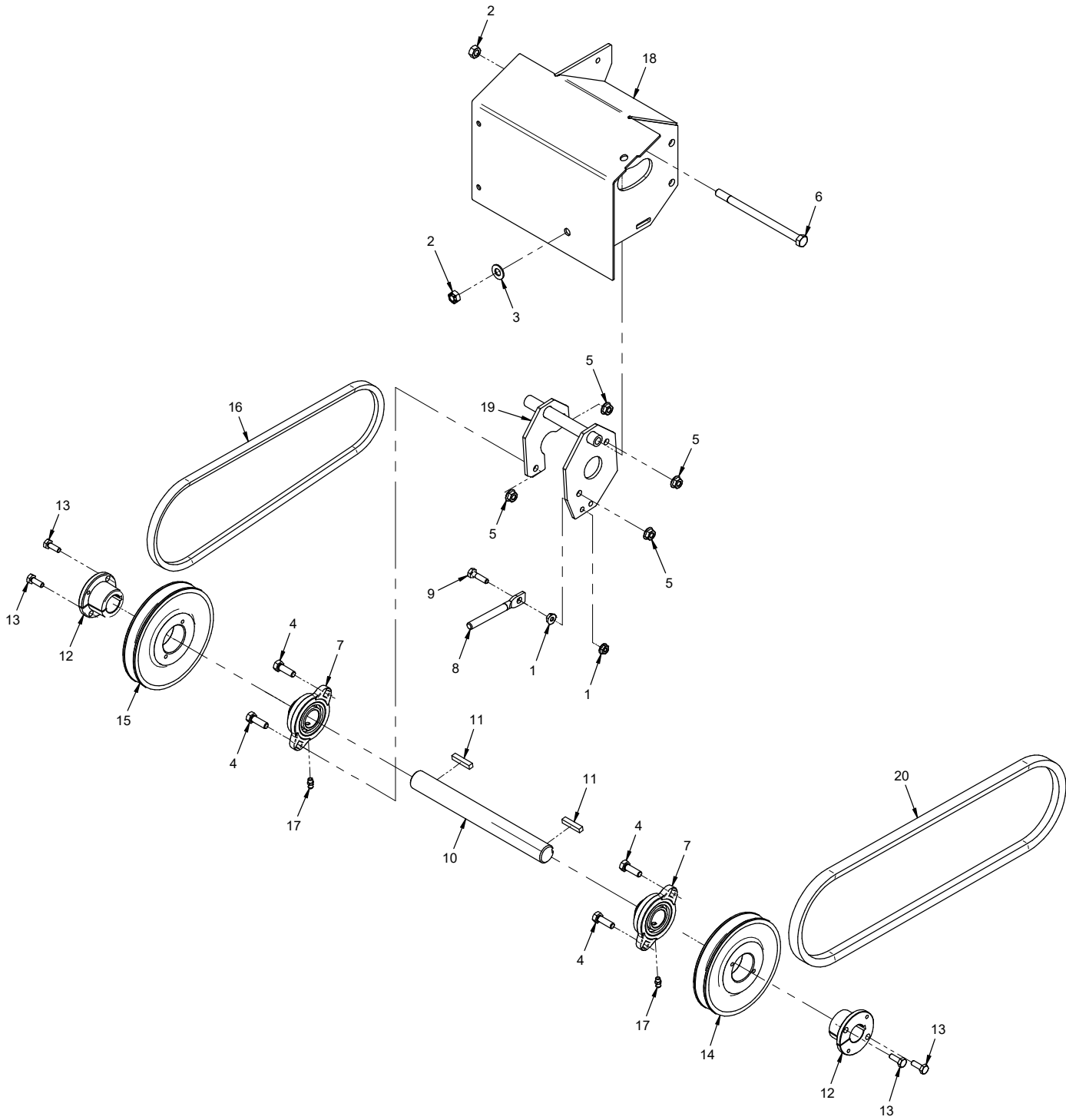

# PARTS

## Optional Blower Drive Shaft

REF.	PART NO.	DESCRIPTION	QTY.
1	99.SF04	NUT, SRF 1/4-20 USS	2
2	99.A06	LOCKNUT, STOVER 3/8-16 USS	2
3	95.06	WASHER, FLAT 3/8 SAE	1
4	90.0508	BOLT, HEX 5/16-18 UNC X 1"	4
5	99.SF05	NUT, SRF 5/16-18 USS	4
6	90.0648	BOLT, HEX 3/8-16 UNC X 6	1
7	55.FB16016-1	BEARING, FLANGE BLOCK 1"	2
8	99.K0113	BOLT, HANGER 3/8-16 X 5	1
9	90.0408	BOLT, HEX 1/4-20 UNC X 1"	1
10	80.0343	SHAFT, TGP A X 9-1/2L	1
11	85.K0410	KEY, 1/4 X 1-1/4	2
12	83.H16S	BUSHING, 1" SPLIT 1/4" KEY	2
13	90.0406	BOLT, 1/4-20 USS X 3/4"	4
14	83.BK55H	PULLEY, 5.5" H-BUSHING	1
15	83.BK60H	PULLEY, 6" H-BUSHING	1
16	81.AX037	BELT, AX37	1
17	29.GF0001	GREASE FTG, 1/4 SAE ST	2
18	62.0976	FRAME, J-SHAFT HOUSING	1
19	62.0977	MOUNT, BEARING FRAME	1
20	81.B045	BELT, B45	1

# PARTS

## ILLUSTRATED DRAWING Optional Blower Fan (D-Hex Spline Pulley & Spindle Shaft)

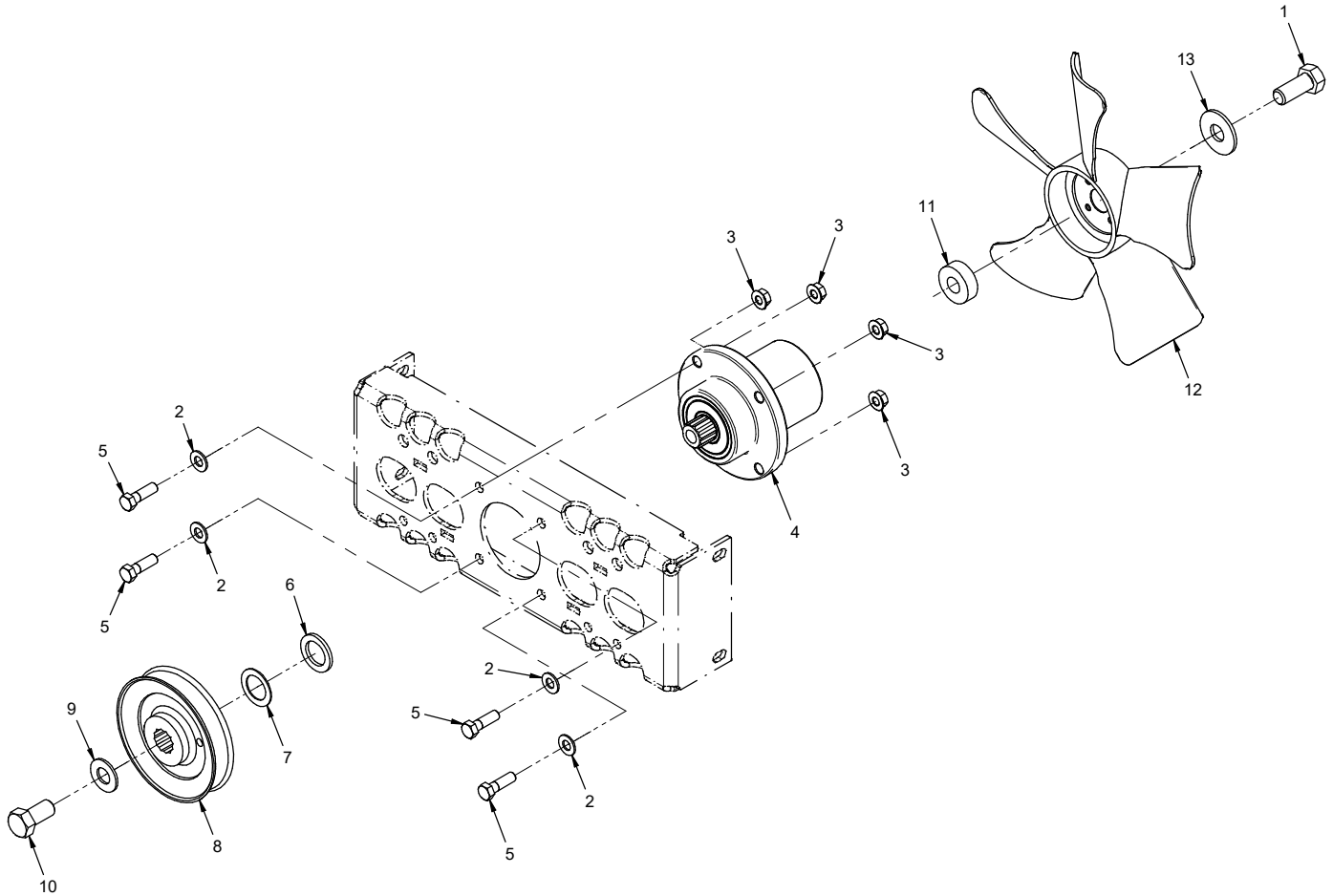

# PARTS

## Optional Blower Fan (D-Hex Spline Pulley & Spindle Shaft)

REF.	PART NO.	DESCRIPTION	QTY.
1	90.1012	.BOLT, HEX 5/8-11 UNC X 1-1/2	1
2	95.06	.WASHER, FLAT 3/8 SAE	4
3	99.SF06	.NUT, SRF 3/8-16 USS	4
4	87.0214	.SPINDLE, ASM RH D-HEX SHAFT	1
5	90.0610	.BOLT, 3/8-16 USS X 1-1/4	4
6	99.B0015	.WASHER, MACH 1" 10 GA.	1
7	99.B0017	.WASHER, MACH 1" 18GA	1
8	83.0033	.PULLEY, 5.2" D-HEX HUB ON TOP	1
9	95.10	.WASHER, FLAT 5/8 SAE	1
10	90.1010	.BOLT, HEX 5/8-11 UNC X 1-1/4	1
11	85.B0081	.BUSHING, .641 ID X 1.5 OD X .5 THK	1
12	13.0201	.FAN, VANGUARD 290MM	1
13	94.10	.WASHER, FLAT 5/8 USS	1

# WARRANTY



## LIMITED WARRANTY - VENTRAC COMMERCIAL EQUIPMENT

Venture Products, Inc., (henceforth referred to as V.P.I.) warrants on the terms and conditions herein, that it will repair, replace, or adjust any part manufactured by Venture Products Inc., and found by Venture Products, Inc., to be defective in material and/or workmanship during the applicable warranty term.

All Ventrac commercial equipment purchased and registered on or after January 1, 2019 will carry a 2-year commercial warranty. The warranty period begins on the date of original customer purchase:

<b>Ventrac Commercial Equipment</b>	<b>Warranty Term</b>
2100 SSV & Attachments	2-year
3000 Series Tractors & Attachments	2-year
4000 Series Tractors & Attachments	2-year

All Ventrac add-on kits and accessories such as: 3-point hitch, 12V front & rear power outlets, foot pedal, dual wheel kit, etc., will be covered under the above warranty periods provided they are installed by an Authorized Ventrac Dealer. This warranty may be transferred and will carry the remainder of the warranty starting from the original purchase/registration date with the dealership and/or V.P.I.

The engine warranty is covered by its respective engine manufacturer. Please refer to the engine manufacturer's warranty statement that is included in the owner's manual.

For warranty consideration on Ventrac commercial equipment, including any defective part, must be returned to an Authorized Ventrac Dealer within the warranty period. The warranty shall extend to the cost to repair or replace (as determined by V.P.I.) the defective part. The expense of pickup and delivery of equipment, service call drive time or any transportation expense incurred for warranty repair is the sole responsibility of the owner and is not covered under warranty by Ventrac and/or V.P.I. Ventrac and V.P.I.'s responsibility in respect to claims is limited to making the required repairs or replacements, and no claim of breach of warranty shall be cause for cancellation or rescission of the contract of sale of any Ventrac equipment. Proof of purchase may be required by the dealer to substantiate any warranty claim. Only warranty work performed and submitted by an Authorized Ventrac Dealer may be eligible for warranty credit.

This warranty extends only to Ventrac commercial equipment operated under normal conditions and properly serviced and maintained. The warranty expressly does NOT cover: (a) any defects, damage or deterioration due to normal use, wear and tear, or exposure; (b) normal maintenance services, such as cleaning, lubrication, oil change; (c) replacement of service items, such as oil, lubricants, spark plugs, belts, rubber hoses, bearings or other items subject to normal service replacement; (d) damage or defects arising out of, or relating to abuse, misuse, neglect, alteration, negligence or accident; (e) repair or replacement arising from operation of, or use of the equipment which is not in accordance with operating instructions as specified in the operator's manual or other operational instructions provided by V.P.I.; (f) repair or replacement arising as a result of any operation from Ventrac equipment that has been altered or modified so as to, in the determination of V.P.I., adversely affect the operation, performance or durability of the equipment or that has altered, modified or affected the equipment so as to change the intended use of the product; (g) repair or replacement necessitated by the use of parts, accessories or supplies, including gasoline, oil or lubricants, incompatible with the equipment or other than as recommended in the operator's manual or other operational instructions provided by V.P.I.; (h) repairs or replacements resulting from parts or accessories which have adversely affected the operation, performance or durability of the equipment; or (i) damage or defects due to or arising out of repair of Ventrac equipment by person or persons other than an authorized Ventrac service dealer or the installation of parts other than genuine Ventrac parts or Ventrac recommended parts.

# WARRANTY

---



## LIMITED WARRANTY - VENTRAC COMMERCIAL EQUIPMENT

The sole liability of V.P.I. with respect to this warranty shall be the repair and replacement as set forth herein. V.P.I. shall have no liability for any other cost, loss, or damage. In particular V.P.I. shall have no liability or responsibility for: (i) expenses relating to gasoline, oil, lubricants; (ii) loss, cost or expense relating to transportation or delivery of turf equipment from the location of owner or location where used by owner to or from any Authorized Ventrac Dealer; (iii) travel time, overtime, after hours' time or other extraordinary repair charges or charge relating to repairs or replacements outside of normal business hours at the place of business of an Authorized Ventrac Dealer; (iv) rental of like or similar replacement equipment during the period of any warranty repair or replacement work; (v) any telephone or telegram charges; (vi) loss or damage to person or property other than that covered by the terms of this warranty; (vii) any claims for lost revenue, lost profit or additional cost or expense incurred as a result of a claim of breach of warranty; or (viii) attorney's fees.

The remedies of buyer set forth herein are exclusive and are in lieu of all other remedies. The liability of V.P.I., whether in contract, tort, under any warranty, or otherwise, shall not extend beyond its obligation as set forth herein. V.P.I. shall not be liable for cost of removal or installation nor shall V.P.I. be responsible for any direct, indirect, special or consequential damages of any nature. In no event shall V.P.I. be liable for any sum in excess of the price received for the goods for which liability is claimed.

There are no representations or warranties which have been authorized to the buyer of the Ventrac commercial equipment other than set forth in this warranty. Any and all statements or representations made by any seller of this equipment, including those set forth in any sales literature or made orally by any sales representative, are superseded by the terms of this warranty. Any affirmation of fact or promise made by V.P.I. or any of its representatives to the buyer which relates to the goods that are the subject to this warranty shall not be regarded as part of the basis of the bargain and shall not be deemed to create any express warranty that such goods shall conform to the affirmation or promise.

No employee, distributor, or representative is authorized to change the foregoing warranties in any way or grant any other warranty on behalf of V.P.I.

Some states do not allow limitations on how long an implied warranty lasts or allow the exclusion on limitation of incidental or consequential damages, so the above limitation or exclusion may not apply to you.

This warranty gives you specific legal rights, and you may also have other rights which vary from state to state.

This warranty applies to all Ventrac commercial equipment sold by Venture Products Inc.