

C15 Mowing, Verticutting & Collecting

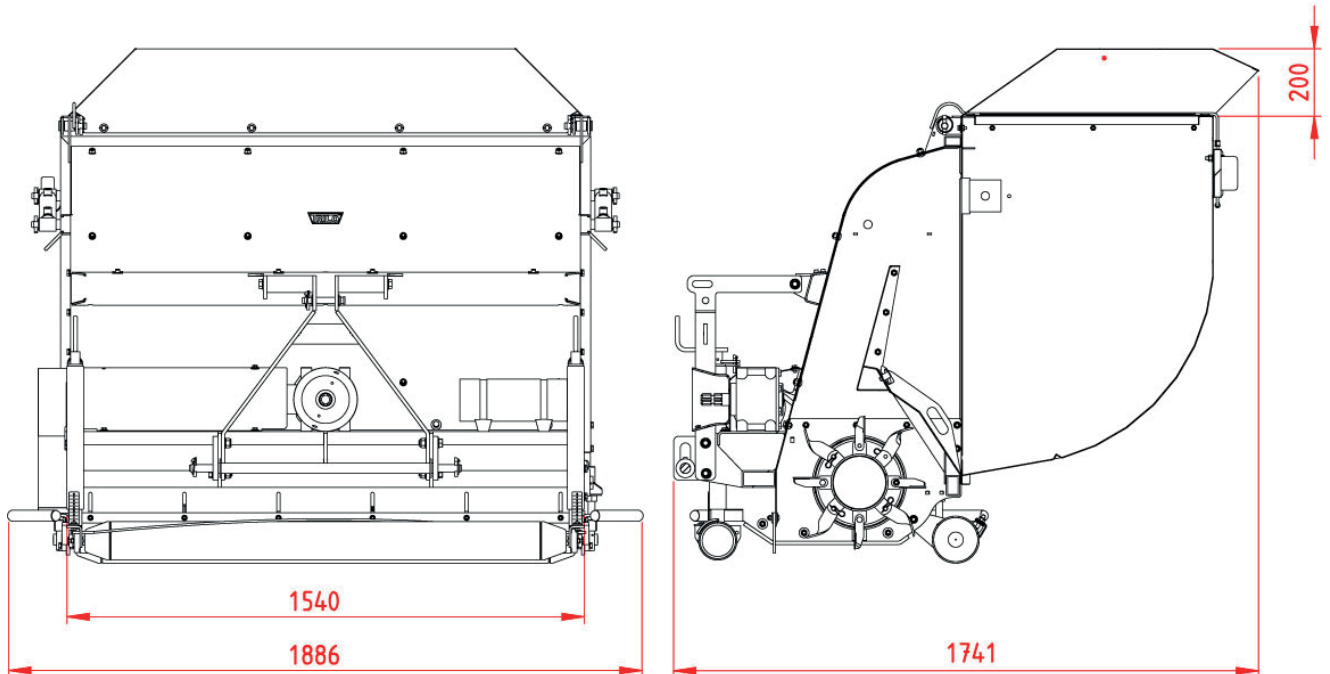

Measures are in mm

Technical specifications

PTO output:	> 30 hp (22 Kw)
PTO:	540 RPM
Drive:	Power take-off
Three point hitch:	Cat. I-II
Required hydraulics:	120 bar - 15 l/min.
Required hydraulic connections:	1 x single acting
Weight:	515 kg (1135 lb)
Measurements (LxWxH):	1,85 x 1,88 x 1,57 m (6 x 6.16 x 5.15 ft)
Loading capacity:	1,1 m ³ (1.43 yd ³)
Working width:	1,50 m (4.9 ft)
Number of knives:	48
Diameter knives:	Rotor: Ø 455 mm (18")
Thickness of knives:	3 mm (0.11")
Knife distance:	26 mm (1.02")
Front roller diameter:	Ø 114 mm (4.48")
Working depth:	Max. 50 mm (1.96")
Number of wind paddles:	18

Under our policy of continuous improvement, we reserve the right to change specifications and design without prior notice. The illustrations do not necessarily show the standard version of the machine.

C15 Mowing, Verticutting & Collecting

