

Operator's Manual and Parts List

TDR-26

Rotary Finish Mowers

Serial No. 1826101 and up



PROGRESSIVE TURF EQUIPMENT INC.
137 WEST WILLIAM STREET
SEAFORTH, ONTARIO
CANADA N0K 1W0
TOLL FREE: 800 668-8873
ISSUE DATE: February 2019
P.N. 120593



The Better Built Choice.™

www.progressiveturfequip.com

TABLE OF CONTENTS	PAGE
INTRODUCTION	3
FOREWORD	3
ITEMS INCLUDED WITH TDR-26 MOWERS	4
SERIAL NUMBER LOCATION	4
REPLACEMENT PARTS INFORMATION	4
UNAUTHORIZED MODIFICATION	4
MISUSE OF EQUIPMENT	5
NOTIFICATION OF UNAUTHORIZED MODIFICATION OR MISUSE	5
PRODUCT DESIGN	5
SPECIFICATIONS	6
COMPONENT IDENTIFICATION	7
SAFETY RULES	8
SAFETY ALERT SYMBOL	8
HAZARD SERIOUSNESS LEVEL	8
GENERAL SAFETY PRECAUTIONS	9
POWER UNIT SAFETY	9
OPERATING EQUIPMENT SAFELY	10
MAINTENANCE SAFETY PRECAUTIONS	11
SAFETY DECALS	14
DECAL LOCATIONS	14
DECAL LISTING	15
ASSEMBLY INSTRUCTIONS	17
SET-UP	17
MOWER DECKS	18
DECK PTO SHAFTS	19
INPUT SHAFT	20
TRANSPORT TIRES	20
BLADE INSTALLATION	20
MOWER SETUP FOR OPERATION	21
HITCH ADJUSTMENT	21
HITCHING THE MOWER TO THE TRACTOR	21
CONNECTING THE PTO DRIVELINE	22
CONNECTING THE HYDRAULICS	23
CONNECTING THE PULL ROPE	23
MOWER SAFETY LOCKS	23
CHECK PTO DRIVELINE DURING MANEUVERS	24
CHECK TIRE CONTACT DURING TURNS	24
DISCONNECTING THE MOWER	25
LONG-TERM STORAGE	25
OPERATING THE MOWER	26
DAILY CHECK LIST	26
DECK LOCK SYSTEM	26
RAISING AND LOWERING THE DECKS	28
ADJUSTING THE CUTTING HEIGHT	28
MOWING	29
PRO LIFT-N-TURN™ OPERATION	29
TRANSPORTING THE MOWER	30
MAINTENANCE	31
LUBRICATION	31

"V" BELT DRIVE.....	35
FASTENER INSTALLATION TORQUE	36
BLADE SERVICING	37
SPINDLE SERVICE	40
HYDRAULICS	42
SUPPORTING MACHINE FOR SERVICE.....	42
TRANSPORT TIRES.....	43
LONG-TERM STORAGE	43
TROUBLESHOOTING	44
NOTES	45

INTRODUCTION

Thank you for purchasing a TDR-26 series mower. Available with both powder coated deck skins and optional galvanized deck skins, this product is designed and manufactured to allow safe and productive mowing of large areas. A well-maintained machine will provide years of reliable service.

FOREWORD

This is the Operator's Manual for the TDR-26 series mowers. Keep it with the mower at all times. This manual is intended as a guide to the safe use and maintenance of the machine, so before you operate this machine, study this manual carefully.

Replace this manual immediately if it becomes lost.

This manual is not considered all-inclusive, so for further information on specific components, e.g. PTO shafts etc refer to the respective documents included with the manual set for this machine.

The TDR-26 series are production turf grass finishing rotary mowers with a 22 foot cutting width, and is designed to be pulled by a 65-75 PTO horsepower tractor. High blade tip speed gives this versatile mower the ability to mow both slightly contoured and flat terrain that requires a high quality after-cut appearance. Full-width steel rollers reduce deck bounce during mowing and allow for higher mowing speeds.

Features:

- Three independent, fully floating decks
- Low power input per cutting width
- Cut height can be set on each deck between 1/2 inch and 4 inches
- Full-width steel rollers on front and rear deck allow increased mowing speed
- Automatic mechanical deck locks for transport
- Optional galvanized steel deck skins for increased service life

Applications:

- Turf grass farms
- Park lands and recreational areas
- Grass runways

OSHA Training Requirements (USA)

The following training requirements have been taken from Title 29, Code of Federal Regulations Part 1928.57 (a)(6). www.osha.gov

Operator Instructions: At the time of initial assignment and at least annually thereafter, the employer shall instruct every employee in the safe operation and servicing of all covered equipment with which he is or will be involved, including at least the following safe operating practices.

In other jurisdictions

It is good practice, following the initial instruction and at least annually thereafter, the employer shall instruct every employee in the safe operation and servicing of all covered equipment with which he is or will be involved, including at least the following safe operating practices.

ITEMS INCLUDED WITH TDR-26 MOWERS

- TDR-26 Operator's Manual & Parts List
- Service instructions for PTO drive shafts and safety clutches
- Cutting Height Adjustment Wrench
- Blade balancer tool

SERIAL NUMBER LOCATION

The serial number plate for the machine is located on the left-hand front frame.

For quick reference, record the following information:

Model: _____ TDR-26 _____
Serial Number: _____
Date purchased: _____

NOTE: The last digit in each TDR-26 serial number is a letter. This letter denotes the deck configuration of the mower.

- Blank - Painted Decks
- G Galvanized Decks

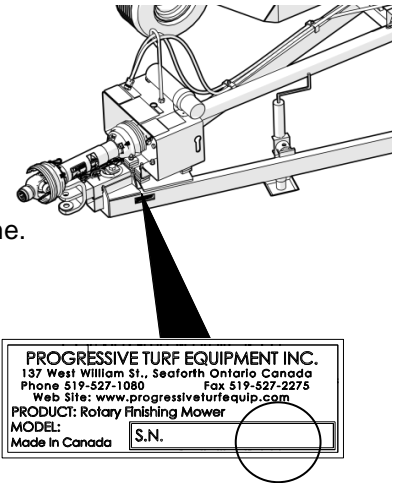

REPLACEMENT PARTS INFORMATION

Use only Genuine Original Equipment Manufacturers (O.E.M.) replacement parts. The use of "will fit" parts may reduce machine performance, void machine warranties and present a safety hazard. Use Genuine OEM parts.



UNAUTHORIZED MODIFICATION

Modifications to the original design of the TDR-26 mower, including the use of unauthorized accessories or non-genuine OEM parts, may affect the reliability of the machine or make it unstable or unsafe to operate and perform as originally designed and intended. Persons or organizations that make unapproved modifications (including operation without provided guards and shields) assume all liability arising from or related to the modification including any adverse effect on the machine.

No modification can be made to the original design or assembly of the TDR-26 mower (including any and all attachments, safety or control devices) without the prior written consent of the Progressive Turf Equipment Inc.'s Engineering Manager (see contact information below). Progressive Turf Equipment Inc. retains the right to reject all claims which arise from or are related to unauthorized modifications.

Modifications are officially approved if at least one of the following conditions is met:

- i. The attachment, accessory or part is distributed by Progressive Turf Equipment Inc. and is intended for a TDR-26 mower application and installed in an approved manner as described in Progressive Turf Equipment Inc.'s provided instructions; or
- ii. The modification has been approved in writing by the Progressive Turf Equipment Inc.'s Engineering Manager.

No other entity is authorized by Progressive Turf Equipment Inc. to provide such approval.

MISUSE OF EQUIPMENT

It is incumbent upon the owner and selling dealer along with their respective employees to warn and discourage users about the misuse of the equipment whenever knowledge of misuse becomes known, whether the act has, is or could occur. Such acts include, but not limited to: riding upon, use of non-OEM parts, operation on unstable or steeper slopes than specified, operating in explosive or fire-hazard areas, modifications that alter the original machine specifications or use other than originally intended, etc.

NOTIFICATION OF UNAUTHORIZED MODIFICATION OR MISUSE

If any person, employee, agent, dealer or distributor becomes aware of any Unauthorized Modification or Misuse of a TDR-26 mower, either past or intended, it is the responsibility of that person to ensure that Progressive Turf Equipment Inc.'s Engineering Manager is notified of the occurrence promptly. That person shall provide; the facts of the occurrence, location, machine serial number, name and contact information of the persons involved.

Send correspondence regarding Unauthorized Modification or Misuse to:

Progressive Turf Equipment Inc.
Box 940, 137 West William St.
Seaforth, Ontario, N0K 1W0
Canada
Attn: Engineering Manager

PRODUCT DESIGN

The TDR-26 mower has been designed and produced using generally acceptable manufacturing processes as is standard in the industry for the type of equipment that is similar to the machine. As such, the useful life of the machine is ten (10) years from the date of manufacture.

The official language of the manufacturer is English.

No responsibility is assumed for translations in other languages, which do not correspond to the original meaning.

Under our policy of continuous improvement, we reserve the right to change specifications and designs without prior notice. The illustrations shown do not necessarily represent the standard version of product offered by Progressive Turf Equipment Inc.

*For clarity, some illustrations used in this manual show depictions with certain components removed. Never operate the machine with any component or guard removed.

SPECIFICATIONS

TDR-26

Tractor Requirement

Size (hp) 75-90.....
PTO Input Speed (rpm) 540
Hydraulic System Requirement	... (1) double-acting circuit with float..
Max. Hydraulic Pressure (psi) 2500

Machine Specifications

Cutting Width (ft) 25' 8"
No. of Blades 14
Turning Radius (uncut circle, in) 0
Cutting Height (in)	Minimum 1/2.....
	Maximum 4
Transport Features	Max. Speed 20 mph
	Safety SMV Sign & Safety Chain.....

Mower Decks

Skin Powder Coat
Configuration	3 deck staggered independent
Suspension	4-way floatation
Construction	Replaceable 3/16 in thick skin with reinforced welded tube frame
Spindles	35mm shaft, double ball bearing with integral blade stiffener
Blades	24" diameter, 5/16" thick. (high-lift solid std. see options below)
Blade Mounting	Two bolts/nuts per blade (No internal threads)
Blade Speed	2914 rpm / 18300 sfpm
Rollers	(6) 6" Dia. Heavy wall steel with replaceable shafts
Roller Bearings	Hex bore (positive drive) with triple lip seals. Ductile Iron housing
Ground Pressure	6 psi

Power Transmission

Input Shaft	Cat. 6 1 3/8 dia – 6 Spline, with auto locking collar
Deck Drive Shafts	Cat. 3 1 3/8 dia – 6 spline with quick connect yokes
Gearboxes	(4) Cast Iron Housing /w Bevel gears
Deck Drive	Fiber reinforced V-Belts
Belt Tensioning	Positive draw bolt tensioner (2 per deck)

Transport Tires (2) Heavy Duty LT305/70R-16, 6 bolt.

Productivity (acres/hr*)	2 mph 6.2
	4 mph 12.4
	6 mph 18.6
	7.5 mph 23

Transport Dimensions (in)	Width 104
	Height 145
	Length 204 (17 ft)

Weight (lb)	Machine 6200
	Tongue (transport) 1450
	Tongue (mowing) 560

Optional *Low-Lift Solid Blades, Pro EZ-Change Blades (Std. & Low Lift)
33x16LL-16.1 Floatation Transport Tires

*assumes no stopping or overlap

COMPONENT IDENTIFICATION

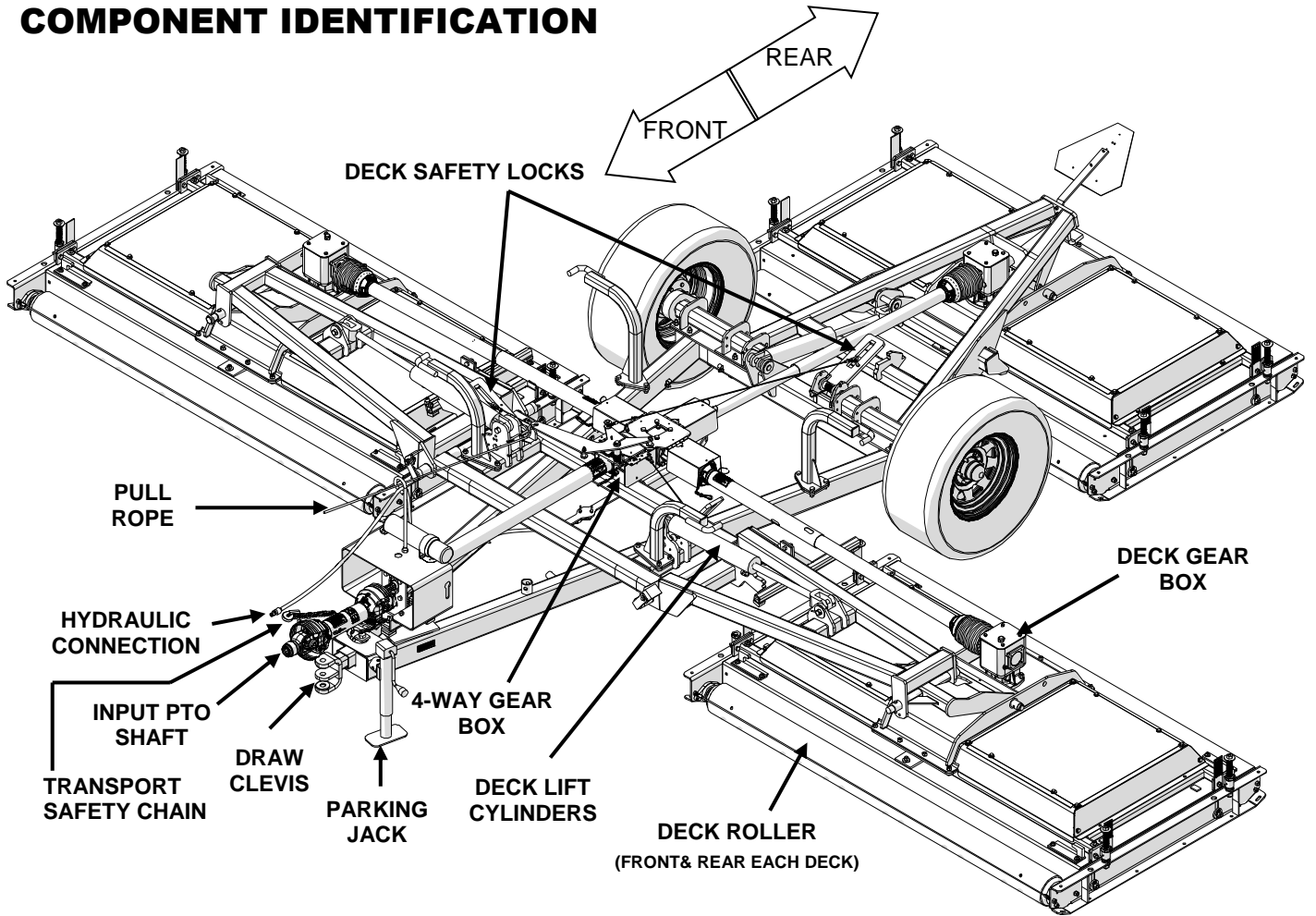

NOTES

- 1) Throughout this manual, references are made to right and left directions. These are determined by standing at the rear of the equipment and facing the direction of forward travel.

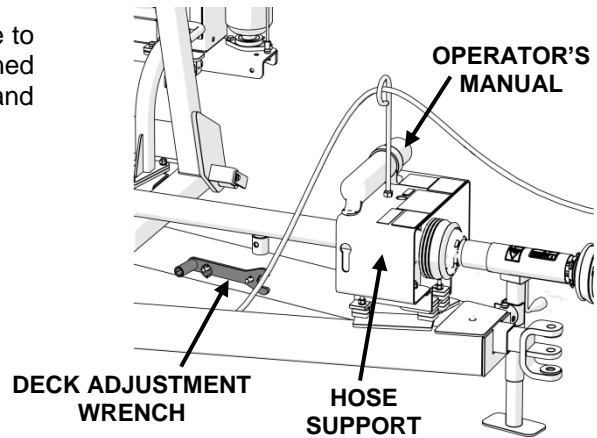

SAFETY RULES

All rotary mowers are potentially dangerous machines; this mower has been designed to minimize the safety risks to the operator, bystanders and property. This section of the Operator's Manual details a number of safety rules pertaining to the operation and maintenance of Progressive Turf Equipment mowers. In order to minimize risks and promote safety at all times, these rules must always be followed and obeyed.

Further safety rules and warning texts are given within the respective sections of this manual.

IMPORTANT! - When it comes to safety, nothing will ever replace a careful operator.

It is imperative that the operator and safety personnel read and understand all of the safety information in this manual before proceeding. Failure to follow the instructions or heed the warnings could result in injury or death.

Proper care is your responsibility.

The manufacturer cannot anticipate every possible circumstance that might involve a hazard. The hazard alerts in this publication and on the product, are therefore not all inclusive. If a tool, procedure, work method, or operating technique not specifically recommended by the manufacturer is used, it is your responsibility to ensure that it is safe for you and others. You should also ensure the machine will not be damaged or made unsafe by the operation, maintenance, or repair procedures you choose. Modifications or adaptations to the machine are not allowed.

Various jurisdictions have specific requirements for work zone safety. Know and adhere to your local requirements. Treat the instructions in this manual as minimum requirements for safe operation.

SAFETY ALERT SYMBOL

This symbol appears at various points in the manual together with a signal word and warning text. It means – Be alert! Your safety is involved. This symbol is used throughout the manual to call attention to areas in which carelessness or failure to follow specific procedures may result in personal injury or component damage / malfunction or both.

HAZARD SERIOUSNESS LEVEL

The following signal words are found throughout the manual together with the safety alert symbol to indicate the seriousness level of identified hazards. Their selection is based on the consequence of human interaction with a hazard.

DANGER! – Hazards or unsafe practices which WILL result in severe personal injury or death.

WARNING! – Hazards or unsafe practices that COULD result in severe personal or death.

CAUTION! – Hazards or unsafe practices that COULD result in minor personal injury or product or property damage



 **DANGER!**

 **WARNING!**

 **CAUTION!**

GENERAL SAFETY PRECAUTIONS

WARNING!

- The operator of this machine must have sufficient knowledge and instructions in the care and operation of this mower and the power unit being used before he / she uses the machine. Do not allow unauthorized persons or children to operate the machine. Do not allow riders on the machine.
- It is the obligation of the operator to make sure that all guards and shields are in place on the machine. Safety decals must be in place and be readable – accidents may otherwise occur. Contact your dealer or the manufacturer for replacement manuals or decals.
- Never use a machine that does not have an operator's manual available. Learn and understand the safety signs and symbols on the machine and the operator instructions before you begin to use the machine.
- Wear personal protective equipment. Know and use the protective equipment that is to be worn when operating or servicing the machine. Hard hats, protective glasses and face shields, protective shoes, gloves, reflector type vests, and ear protection are types of equipment that may be required. Prolonged exposure to loud noise can cause hearing damage.
- Never operate a mower while under the influence of drugs or alcohol. These make reflexes slow and put you and others in grave danger. Always make sure you have full concentration while mowing.
- Adhere strictly to all regulations at the worksite pertaining to the operation of this equipment.
- Always disengage power takeoff (PTO) when transporting or traveling between work sites.
- Be prepared for emergencies. Have a first aid kit, fire extinguisher and emergency contact information available at the work site.

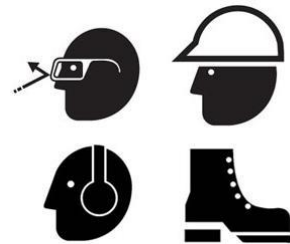

POWER UNIT SAFETY

WARNING!

- The operator must have sufficient knowledge in the care and operation of the power unit (tractor) before connecting power unit to mower. Read and understand power unit operator's manual before connecting mower.
- Power unit must be equipped with ROPS and seat belt. Foldable ROPS must be secured in the upright position. Follow recommendations of power unit manufacturer. Seat belt must be worn at all times.
- Power unit must be equipped with a 1-3/8" 6 spline 540 RPM PTO connection. Never use PTO adapters to connect implements. Never connect mower driveline to 1000 RPM PTO.
- Hydraulic circuits to control mower functions must be set to 2500 psi maximum working pressure.

OPERATING EQUIPMENT SAFELY

WARNING!

- Never allow persons to stand between power unit and mower while backing power unit up to hitch the mower.
- Before hitching mower to power unit, place transmission in neutral, set park brake, and turn engine off. Remove the ignition key.
- Make sure locking collar on PTO shaft is properly locked. If the PTO shaft comes off during operation, personal injury or equipment damage could result.
- Tall grass can hide obstacles. Carefully walk the entire area to be mowed beforehand. Look for debris, rocks, tree limbs etc. that will damage or be thrown by the mower blades. Identify objects that cannot be removed. Set mower cutting height to avoid contact.
- Disengage the PTO when crossing gravel areas or roadways.
- Disengage the PTO and turn power unit off upon striking any object. Inspect mower and repair any damage before continuing. Mower blades can cause small objects and debris to be thrown from under the mower deck at high speeds, up to 300 ft away. Objects ejected by the mower blades can cause severe injury.
- If the equipment should start to vibrate abnormally during operation, stop the mower, shut down power unit, and immediately check for the cause. Excess vibration is generally an indication of a problem. Replace bent or damaged parts, do not attempt to straighten a bent blade.
- Ensure that no bystanders are within 10 ft of mower when wing transport locks are released.
- Keep all bystanders well away from the machine when it is operating. Always maintain a safe operating distance from personnel, other equipment, or vehicles.
- Never operate the mower with shields or guards removed.
- Never tamper with safety devices or operate the mower with them removed. Check proper operation regularly.
- Always disengage PTO, place all controls in neutral, turn power unit off, set parking brake, and remove key before dismounting, for any reason.
- Never place hands or feet under mower deck when the mower is operating, or power unit engine is running.
- Use extreme care when operating on uneven terrain.
- Reduce speed when operating on slopes during wet conditions, especially when making sharp turns.
- Do not use the mower in limited visibility (e.g. at dusk, in fog, heavy rain etc.). Mow only in daylight or good artificial light.
- Disengage PTO and ensure blades are completely stopped before raising wings.
- Ensure deck safety locks are securely engaged before transporting mower with wings in raised position.
- Be aware of over-head obstacles such as trees, building overhangs when transporting mower.

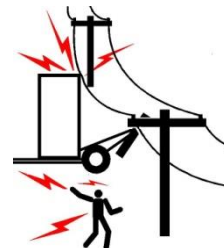
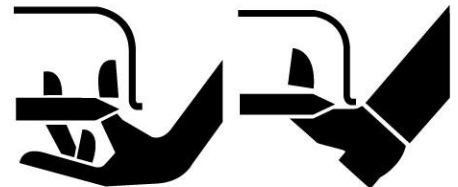

- Keep away from overhead electrical lines. Electrocutation can occur without direct contact
- Clean reflectors, Slow Moving Vehicle sign and lights before transporting. Use power unit hazard lights.
- Before disconnecting from power unit, always place controls in neutral, set park brake, turn engine off, and wait for all moving parts to stop. Relieve hydraulic pressure per power unit manufacturer's instructions.
- Ensure mower parking jack is securely fastened to mower frame with supplied pin before removing hitch draw pin.

MAINTENANCE SAFETY PRECAUTIONS

WARNING!

- Never make adjustments or repairs with the engine running. Always disengage PTO, engage parking brake, turn engine off, lower wings to cutting position and relieve hydraulic pressure before performing any maintenance.
- Observe and perform proper lock-out procedures for power unit if attached to mower during service.
- Keep nuts and bolts tight and properly torqued, especially blade attachment bolts. Check that all cotter pins are properly installed. Keep equipment in good condition.
- Keep mower free of grass, leaves, or other debris build-up.
- Never work on raised mower decks without safety locks in place.
- Periodically check condition of safety devices, guards, and deflectors. Replace only with manufacturer's recommended parts.
- Inspect and replace damaged blades. Use only original OEM parts. Blades can fail from poor maintenance practices.
- Handle mower blades carefully. They are sharp and can cut unprotected skin. Use caution and wear gloves when handling them.
- Check to make sure hydraulic hoses are not worn or damaged and are routed to avoid chafing.
- Immediately replace any hydraulic hose that shows signs of swelling, wear, leaks or damage so it does not burst.
- Do not use your hand to check for hydraulic oil leaks. Use a piece of cardboard instead.
- Hydraulic fluid escaping under pressure can penetrate the skin causing serious injury. If skin penetration occurs, seek medical attention immediately. Relieve all pressure before disconnecting hoses.
- Do not bend or strike hydraulic lines, tubes or hoses, or reinstall them in a bent or damaged condition.

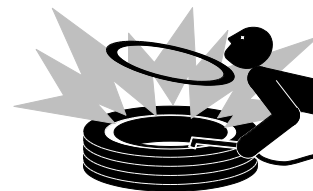

- Inspect tires daily for wear or damage. Check tire pressures weekly with an accurate pressure gauge. Do not inflate tires beyond 35 psi.
- Mounting and dismounting tires from rims can be dangerous and should be performed by trained personnel using correct tools, equipment and procedures.
- Never perform service on a machine that is supported solely by a jack. Always ensure proper blocking is placed to support load during service. **Do not support the machine on cinder blocks, hollow tiles or other members that may fail under continuous load.**



WELDING AND GRINDING WORK PRECAUTIONS

IMPORTANT! A fire extinguisher should be easily accessible during all welding work.

Welding repairs are to be performed by a trained welder with proper service instructions. Know the material to be welded and select the correct welding procedure and materials (electrodes, rods, wire) that will provide a weld metal strength equivalent to the parent material.

Move the machine to a clean, safe area before welding, grinding or using a cutting torch on it. This type of work should only be done in a clean area and not in places that contain combustible liquids, such as fuel tanks, hydraulic pipes or similar.

Connect arc welder ground as close as possible to work area.

Work with extra care when welding, grinding or torch cutting near flammable objects.

WORKING ON PAINTED SURFACES

Heated paint gives off poisonous gases. Therefore, paint must be removed from an area with a radius of at least 4 in (10 cm) before carrying out welding, grinding, or gas cutting. In addition to the health hazard, the weld will be of inferior quality and strength if the paint is not removed.



WORKING ON GALVANIZED / PLATED SURFACES

Only qualified welders should attempt a weld repair on galvanized or plated components. Proper pre-welding surface preparation is required.

Always ensure proper ventilation, wear proper respiratory protective equipment and avoid direct contact with smoke emitted from welding process.

HYDRAULIC SYSTEM SERVICE PRECAUTIONS

WARNING! Risk of personal injury! Wear safety glasses and use protective gloves.

Relieve all trapped pressure before performing any service to the hydraulic system. Pressure can be maintained in the hydraulic circuits long after the power source and pump have been shut down.

Relieve all pressure before disconnecting hoses or tubes.

Tighten all connections before applying pressure.

It is important that each person who comes in contact with the machine be alert to any faults.

Follow these basic precautions:

- Never adjust a pressure relief valve or other pressure-limiting device to a higher pressure than specified.
- Check to make sure hydraulic hoses are not worn or damaged, and are routed to avoid chafing.
- When connecting mower to tractor ensure hydraulic hoses have sufficient slack for negotiating turns and uneven terrain.
- Immediately replace any hydraulic hose that shows signs of swelling, wear, leaks or damage so it does not burst.
- Do not use your hand to check for hydraulic oil leaks. Use a piece of cardboard instead. Hydraulic fluid escaping under pressure can penetrate the skin causing serious injury. If skin penetration occurs, seek medical attention immediately. Relieve all pressure before disconnecting hoses.
- Do not bend or strike high-pressure lines, tubes or hoses, or reinstall them in a bent or damaged condition.

**HYDRAULIC OIL HANDLING PRECAUTIONS**

Oils can irritate and damage the eyes, throat, and sensitive skin. Avoid contact.

Petroleum based oils are hazardous to the environment. Take special care not to spill or discharge these fluids. Use approved containers and methods to handle and dispose of them.

Use authorized disposal and recycling methods per jurisdictional requirements.

SAFETY DECALS

DECAL LOCATIONS



If decals become faded, damaged, or lost, replace immediately.
 Order TDR-26 Decal Kit 526012

ITEM	DESCRIPTION	QTY	ITEM	DESCRIPTION	QTY
1	DANGER – READ MANUAL	1	11	PROGRESSIVE DECAL	2
2	CAUTION - TURNING	1	12	MODEL DECAL	2
3	CAUTION – REPLACE SHIELDS	8	13	CAUTION - PTO ALIGNMENT	1
4	COMPANY NAME	1	14	WING DECK BELT LAYOUT	2
5	DANGER - BLADE HAZARD	7	15	REAR DECK BELT LAYOUT	1
6	WARNING – OEM PARTS	1	16	CE – ROTATING DRIVELINE	5
7	CAUTION – DISENGAGE PTO	1	17	DANGER – ROTATING DRIVELINE	5
8	GREASING SCHEDULE	1	18	DANGER – GUARD MISSING	5
9	PTO GREASING	1	19	WARNING - BLADE HARDWARE	1
10	NOTICE – HITCH SETUP	2	20	GREASE POINT	14

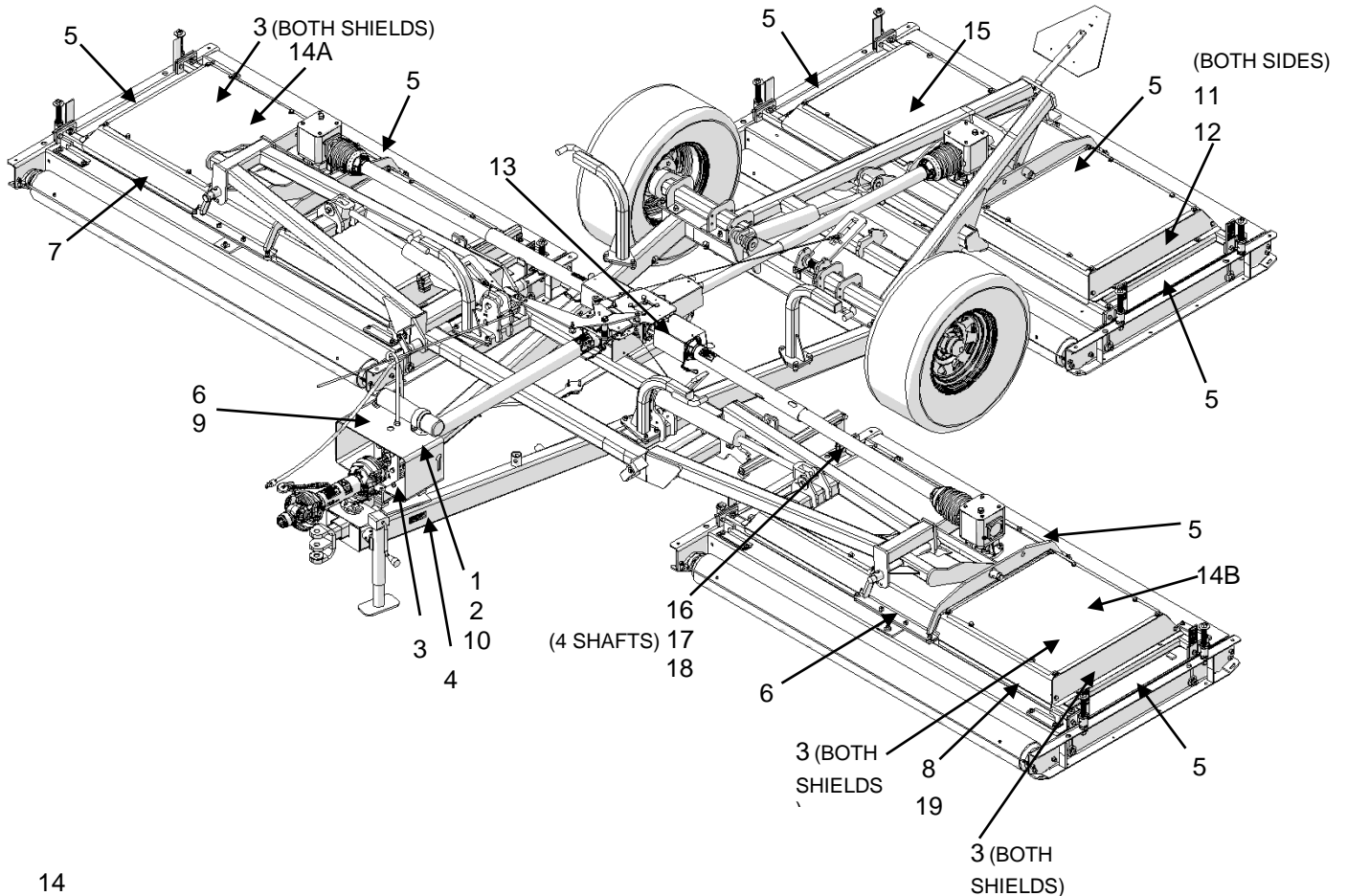

DECAL LISTING

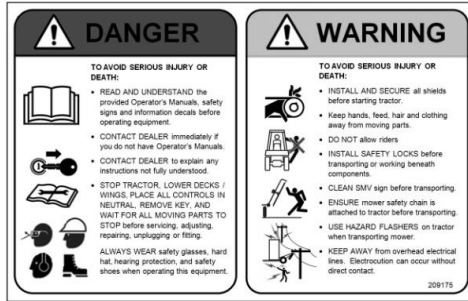

ITEM 1
209175

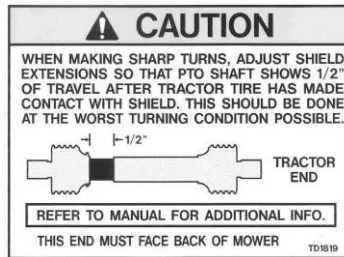

ITEM 2
209171



ITEM 3
209113



ITEM 4
521817



ITEM 5
209173



ITEM 6
209115



ITEM 7
521820



ITEM 8
526003

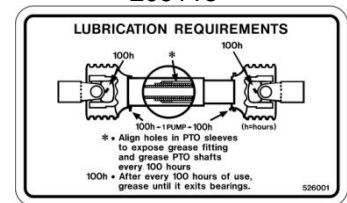

ITEM 9
526001

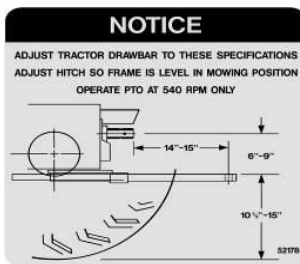

ITEM 10
521784

PROGRESSIVE

ITEM 11
209103

TDR-26 ROLLER MOWER

ITEM 12
209179

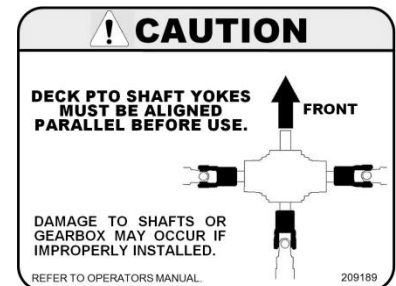

ITEM 13
209189

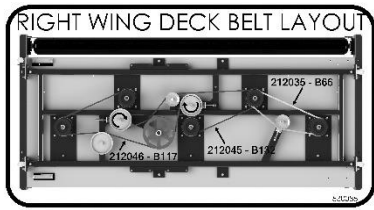

ITEM 14A
530085

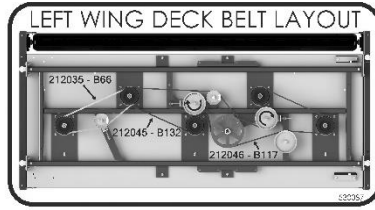

ITEM 14B
530087

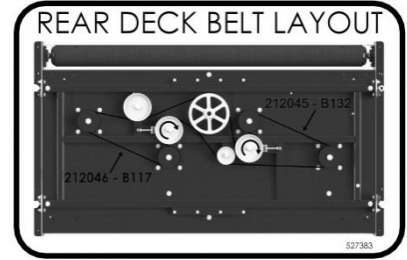

ITEM 15
527383



ITEM 16
210238



ITEM 17
210239



ITEM 18
210237

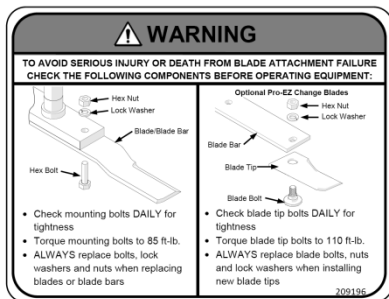

ITEM 19
209196



GREASE POINT DECAL
521014

ASSEMBLY INSTRUCTIONS

SET-UP

The mower is shipped in a partially assembled condition to facilitate shipping of the mower in enclosed vans. For domestic truck shipping the mower is fully assembled with the exception of the wing decks (fully assembled, stacked on steel legs on the main frame) and deck & input PTO shafts requiring installation upon delivery. For overseas container shipping, the (3) mower decks (less rollers and side channels) are shipped stacked on steel legs, deck rollers & side channels are shipped on separate pallets. All other components are packaged with the main frame.

The machine parts list can be used as a graphical reference for assembly.

Approximately 1 1/2 hours (domestic) or 3 1/2 hours (overseas) are required to complete the mower to field ready condition. Assembly will be easier if components are aligned and loosely assembled before tightening hardware. **Recommended torque values are found on page 36.** Select a suitable working area. A tractor or portable hydraulic supply is necessary to complete assembly.



Domestic Truck Shipping Arrangement

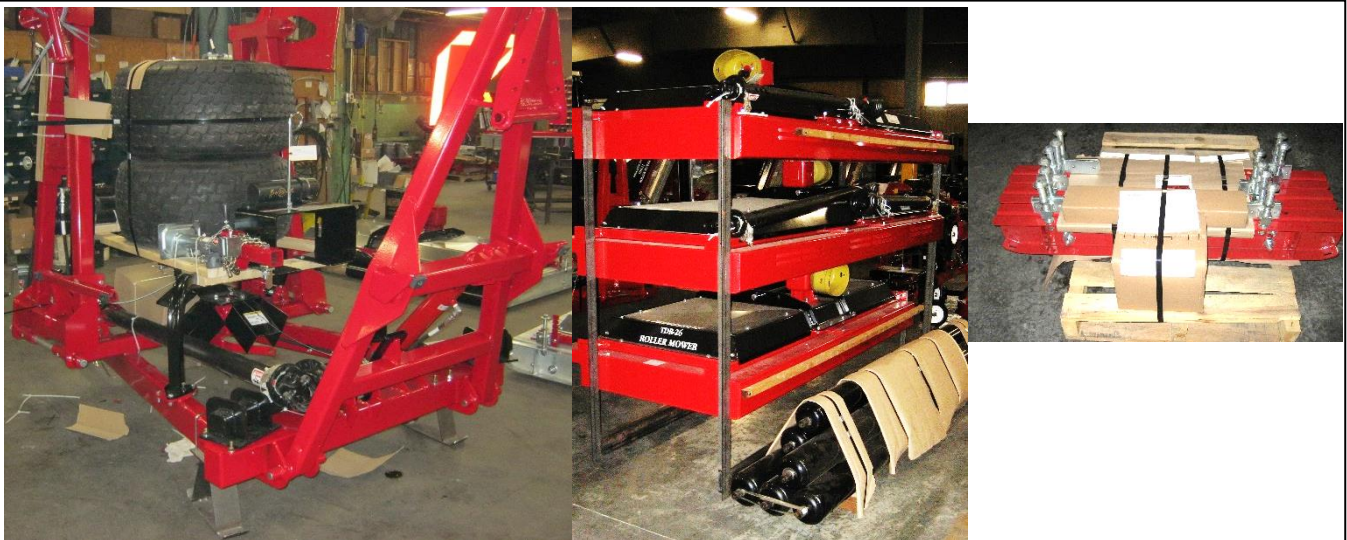

Overseas Container Shipping Arrangement



WARNING!

Exercise extreme caution when releasing shipping straps from mower wings.

Ensure wing locks are securely engaged before releasing shipping straps (see page 23)



CAUTION!

Assembly should be completed by a competent individual who has an understanding of safe machinery operation practices and tool operation. Always use personal protection devices such as eye and ear protection during assembly. Ensure the area is free of hazards and can accommodate the assembly of the mower

MOWER DECKS

Ensure the mower frame assembly is positioned in a level work area, with adequate space for assembly

The TDR-26 decks must be lifted from the shipping stand.

- Ensure proper devices are used to lift deck (approximate deck weights: 850lb – Container shipping, 1550lb – Domestic truck shipping).
- Securely fasten lifting device to deck assembly and ensure deck assembly is supported by the lifting device before removing fasteners securing deck assembly to legs.

- 1) Lift the top deck away. Place the mower deck in the appropriate position at the mower.
- 2) Repeat for the remaining deck(s).
- 3) Remove & retain the painted 1-1/4" pins shipped in the deck swivel bushings.
 - 4) Connect the mower to a hydraulic supply. Retract the hydraulic cylinders and release the deck locks.



CAUTION!

Never retract the wing cylinders into the lift and turn position when the decks are not attached to the wings. You will damage the wing and lock components; the force the cylinders supply is too great without the counterweight of the decks.

- 5) Lower the wing until the deck swivel mounting points align with the bushings on the wing deck swivel. Re-install the painted 1-1/4" pins through the bushings and deck swivel. Secure the pins in place using the 3/8" bolts previously removed.
- 6) Install deck stop chains on wing decks
- 7) When it is safe to do so, fully raise the decks and secure each deck in the transport position with the corresponding deck locks. Ensure the deck locks function properly without binding and engage the matching lug on the wing arm properly. Insert the lock pins in the transport position before moving the mower (Page 26)
- 8) Inspect the front and rear stand-off arms and ensure that they engage the deck lock mounts properly. If required, lower deck to ground, loosen (3) mounting bolts on frame, adjust location of stand-off pin accordingly and re-tighten bolts. Raise deck and re-check stand-off engagement.

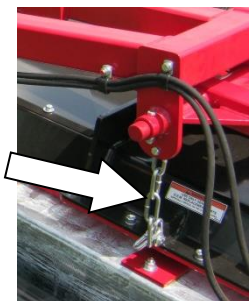

DECK PTO SHAFTS

Each deck on the TDR-26 mower is driven by a dedicated PTO shaft from the 4-way gearbox centrally located on the machine frame. Each deck PTO shaft has one end marked "tractor end"; this end must be connected to the 4-way gear box (There is no bell guard on this end).

The deck pto shaft yokes must be properly phased (timed) when connected to the 4-way gear box. As shown in the illustration to the right; install all deck shaft yokes in the same orientation (shown with yokes installed "flat").

***NOTE – Some guards have been removed in illustration for better clarity. Ensure all guards are reinstalled before operating mower.**

CAUTION!

Failure to install deck PTO shafts with proper phasing can lead to failure of PTO shaft yoke(s) and/or the gear box when decks are raised into transport position.

All PTO shafts feature non-rotating guards that require proper tethering to the machine. Ensure the tether chains at each end of PTO shaft are securely fastened to the mower framework with sufficient slack as to not bind or pull as the decks are raised and lowered. The chain fastening points for both ends of the wing deck shafts are shown below.

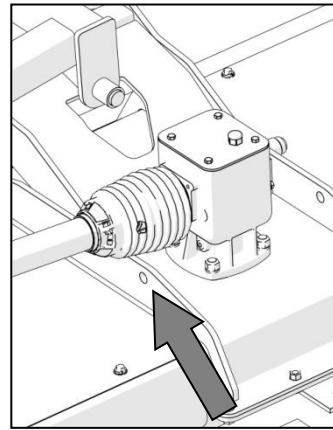
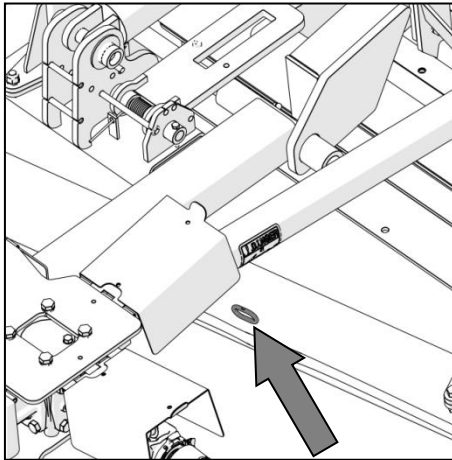
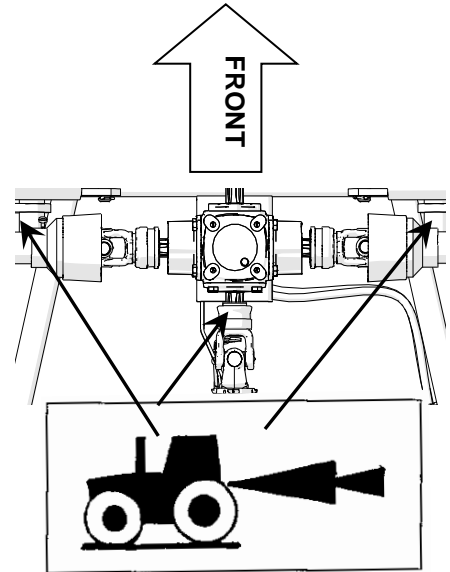

INPUT SHAFT

- 1) Remove ½" UNC retaining bolt/nut from input shaft.
- 2) Remove notification tag from intermediate shaft hanger bearing, ensure gold coloured spacer ring is present against bearing inner race.
- 3) Disconnect input shaft shield at clamp yoke end and slide shield exposing the clamp yoke (see input shaft service instructions in mower manual storage tube).
- 4) Install input shaft clamp yoke on intermediate shaft, ensuring gold coloured spacer ring is in place between the input shaft yoke and hanger bearing race.
- 5) Reinstall ½" UNF retaining bolt in input shaft yoke, torque to 85 ft-lb.
- 6) Reinstall input shaft shield per input shaft service instructions.
- 7) Fasten input shaft guard retaining chain to mower main frame with sufficient slack as to not bind or pull during turns.

TRANSPORT TIRES

- 1) Check air pressure in the tires and adjust according to specifications on sidewall

BLADE INSTALLATION

Blades & attaching hardware for the TDR-26 mower are shipped loose with the machine and must be installed before use. Blades must be installed in accordance with instructions on page 37 of this manual.

MOWER SETUP FOR OPERATION

WARNING!

Always refer to tractor operator's manual for specific detailed information regarding operation of equipment.

Always ensure the tractor controls are in the park position, the engine is turned off, the parking brake is engaged and hydraulic pressure to the tractor remote connectors has been relieved when working around tractor during setup procedures.

HITCH ADJUSTMENT

Before hitching the mower to the tractor, ensure tractor drawbar is set properly. Having the proper hitching dimensions for the tractor drawbar and the PTO, will ensure long and trouble-free hours of operation. **Incorrect setup may lead to driveline vibration and reduced component life.**

The decal shown is mounted to the machine and indicates these important hitch dimensions.

- 1) The drawbar length must be adjusted so it is 14" to 15" from the end of the PTO shaft to the center of the draw pin.
- 2) The top of the drawbar must be adjusted so it is 6" to 9" from the center of the PTO shaft to the top of the drawbar.
- 3) The main frame of the mower should be level when hitched to the tractor.
- 4) The draw clevis can be mounted in 2 positions (flip over) for adjustability.
- 5) Using the supplied 1/2" spacers, adjust the height of the hanger bearing mount so that the input PTO shaft is in-line with the tractor PTO.

HITCHING THE MOWER TO THE TRACTOR

WARNING!

Crushing Hazard between tractor and mower. Never allow anyone to stand between tractor and mower while backing-up to the mower

- 1) Back the tractor to the hitch clevis.
- 2) When the draw pin holes are aligned, place the tractor controls in the park position, shut the engine off and engage the parking brake.
- 3) Place the draw pin in the draw pin hole connecting the mower to the tractor.
- 4) Connect the transport safety chain to the tractor. The chain must pass through the tractor intermediate support and be attached securely to the frame of the tractor (see illustration). Ensure there is no more slack in the safety chain than necessary
- 5) Raise parking jack fully and place in storage position. Remove the parking jack attachment pin, move jack to storage position and insert attachment pin. (see illustration)

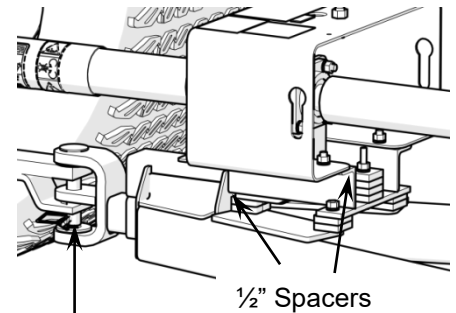
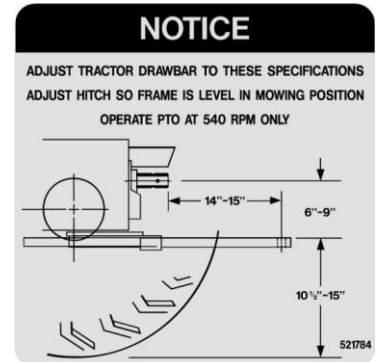

Adjustable draw clevis

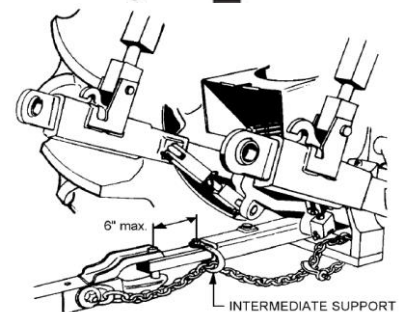

CAUTION!

Replace safety chain if one or more links or end fitting is broken, stretched or otherwise damaged or deformed.

CONNECTING THE PTO DRIVELINE

- 1) Ensure that the tractor engine is shut off, the parking brake is engaged and the mower is securely hitched to the tractor.
- 2) Apply a light coat of grease to the Tractor PTO splines.
- 3) Slide the input shaft locking collar backwards, opening the locking mechanism. Locking collar should remain in an open position
- 4) Hold the splined input yoke against the end of the tractor PTO shaft; rotate either the tractor PTO or input driveline by hand until the shaft slides on slightly.
- 5) Slide the yoke fully onto the tractor's PTO, the locking collar should automatically engage when the yoke is properly engaged with the tractor PTO.
- 6) Attempt to move the shaft forward and backwards to ensure that it is securely locked in place.
- 7) Attach the PTO cover safety chain to the tractor. Ensure cover is properly retained by the chain on the mower end.

WARNING!

If the PTO driveline becomes detached during operation, it may cause personal injury and damage to the driveline and tractor PTO. Always ensure the locking collar is properly engaged.

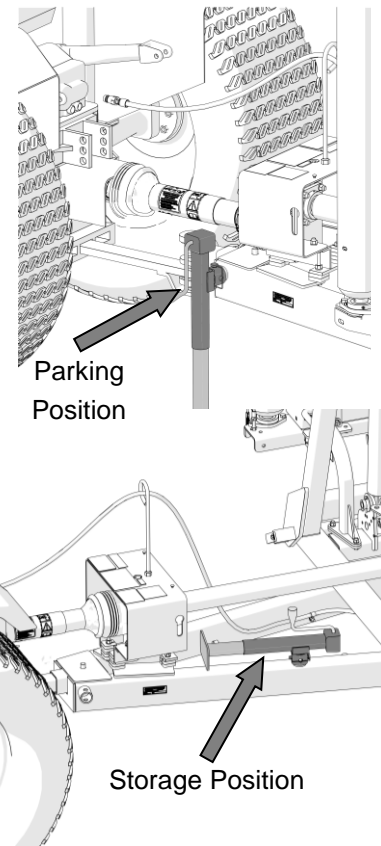

CONNECTING THE HYDRAULICS

- 1) Ensure the tractor controls are in the park position, the engine is turned off, the parking brake is engaged and hydraulic pressure to the tractor remote connectors has been relieved per the tractor operator's manual instructions.
- 2) When connecting the hydraulic coupler to the tractor, be sure that the end is clean. Dirt in the hydraulic system can block the orifice in the cylinder and cause premature wear of hydraulic components on the mower and tractor.
- 3) Ensure the hose is free to move, between the tractor and mower. During operation of the mower going up and down the hills, the distance between the tractor and mower will change.

WARNING!

Hydraulic fluid escaping under pressure can penetrate the skin causing serious injury. If skin penetration occurs, seek medical attention immediately.

CAUTION!

Tractor control valves must be equipped with float function. Failure to use float function during mowing may damage the mower.

CONNECTING THE PULL ROPE

The TDR-26 mower is equipped with a nylon pull rope that is connected to the wing deck release mechanism, used for locking the mower decks into transport position. Connect it to the tractor in a position that is easily accessible to the operator and will release easily if the mower should ever become disconnected from the tractor.

MOWER SAFETY LOCKS

Safety locks are provided for each deck to prevent each from unexpectedly lowering from the transport position in the event of a failure in the hydraulic system.

Each deck features an automatically activated safety lock located on the main frame of the mower.

In order to lower the wings:

- 1) Remove stop pin from each lock and place in storage location (See page 26)
- 2) Fully raise the wings (they may have settled against the lock during transport or storage).
- 3) From the operator station in the tractor, pull and hold the pull rope to disengage the locks.
- 4) Lower the wings to the working position using the tractor hydraulic control.
- 5) Release the pull rope when the wings are lowered.

WARNING!

Ensure safety locks are properly engaged before attempting to transport or service mower.

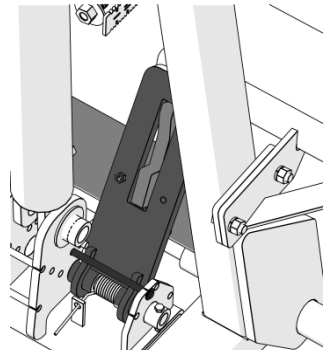
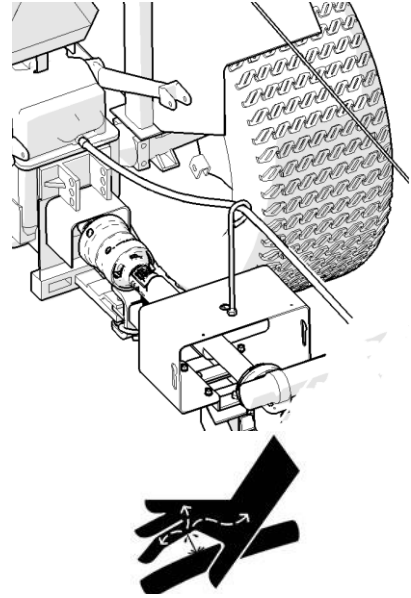

Wing Lock
(2 Places)

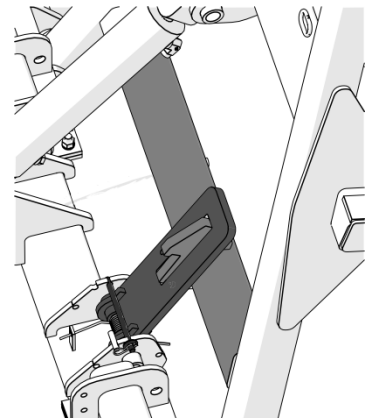

Rear Deck Lock
(1 Place)



CHECK PTO DRIVELINE DURING MANEUVERS

The TDR-26 mower is designed for mowing of uneven, contoured landscape. When negotiating turns, the input PTO shaft will change in length. During mowing of steep contoured conditions, when the tractor starts up a hill the input shaft will collapse and when cresting the hill, it will extend. It is important to make sure that the input shaft does not fully collapse, over-extend or contact the hose support or hose support rod during turns or when travelling over hills.

To ensure proper setup check the following conditions:

- 1) With the tractor in the lowest gear and travelling very slowly, make a sharp turn to the right.
- 2) Watch the driveline shielding to make sure the input shaft does not totally collapse. There should be a minimum of 1/2" of the inner black shielding exposed at maximum turn.
- 3) Ensure input shaft shielding does not come in contact with hose support or hose support rod.

NOTE: This is not the worst condition. Making turns while the tractor is angling up a hill will cause the PTO shaft to collapse even more. Likewise, traveling straight up or down a hill will either extend or collapse the PTO shaft. The operator should avoid making sharp turns on uneven terrain.

WARNING!

If the PTO over extends, it will come apart and can cause injury to the operator or damage to the mower or tractor.

CAUTION!

If the input PTO shaft collapses fully, it will force the shaft back against the hanger bearing. This will cause damage and premature failure of the bearing.

CHECK TIRE CONTACT DURING TURNS

The TDR-26 mower features a hose support which also serves the function to limit the steering angle of the mower without damage to components. In proper operation, the tractor tire should contact the hose support first if the operator attempts to turn too sharp without damage to the drive-line.

To check tire contact:

- 1) With the tractor in the lowest gear and travelling very slowly, make a sharp turn.
- 2) As you turn, watch closely to make sure the tractor tires contact the hose support. (not other parts of the mower)
- 3) If the tires do not contact the hose support, adjust tractor tire width (if possible), so they contact the hose support. Contact us for a modified guard.

NOTE: With proper adjustment, the tire will contact the hose support and will not allow the tractor to turn any further. It will either, prevent the contacted tire from turning, spin the opposite tire, or push the front of the tractor around. This guard will not work with lug style tires.

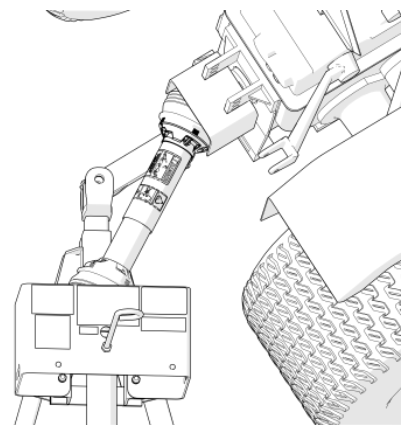

DISCONNECTING THE MOWER

In order to prevent collection of rain water on the mower decks, the mower should be stored with the decks in the raised position. Ensure the safety locks are securely engaged before disconnecting the mower from the tractor.

- 1) Place mower on a level surface for storage.
- 2) Ensure that the tractor engine is shut off and the parking brake is engaged.
- 3) Inspect deck safety locks to ensure they are properly engaged (if in the raised position).
- 4) Move the lock pins in to the "Transport" position (See page 26).
- 5) Relieve pressure in the hydraulic hoses per tractor manufacturer's instructions (normally cycling the tractor control valve in both directions is sufficient).
- 6) Chock mower transport tires to ensure mower does not roll unexpectedly when hitch pin is removed.
- 7) Disconnect pull rope from rear of tractor and hook on hose support rod.
- 8) Disconnect hydraulic couplers from tractor & stow in supplied locations in the sides of the hose support.
- 9) Disconnect the transport safety chain from the tractor.
- 10) Disconnect input shaft guard chain from tractor. Slide the mower input shaft locking collar backwards, opening the locking mechanism. Locking collar should remain in an open position.
- 11) Remove input shaft from tractor (collapsing sliding shaft).
- 12) Move the parking jack from the storage position to the parking position. Raise the parking jack sufficiently to remove all mower weight from the tractor drawbar. **Ensure mower parking jack is securely fastened to mower frame with supplied pin before removing hitch draw pin**
- 13) Remove draw pin from hitch.
- 14) Ensure drain holes in deck surface are free from grass clippings or other debris.

LONG-TERM STORAGE

If the mower will not be used for an extended period, certain activities must be performed. See "Long-Term Storage" in the Maintenance section.

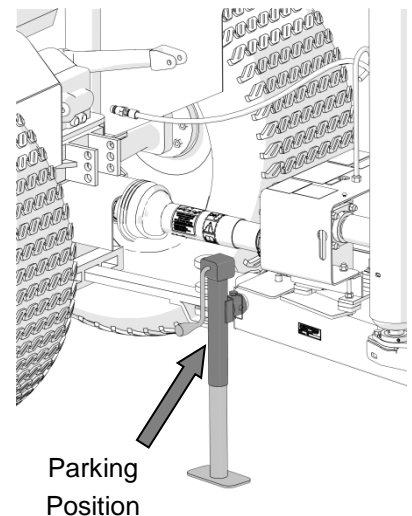
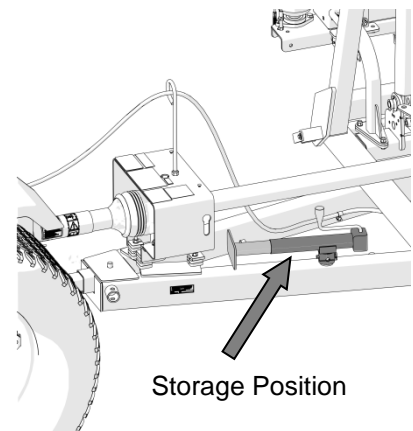
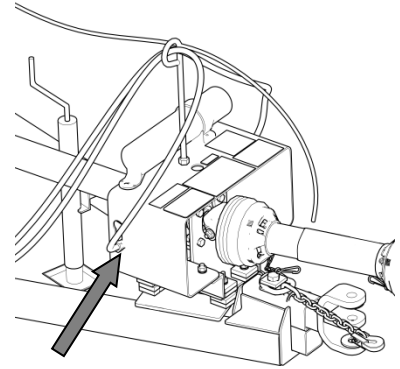

OPERATING THE MOWER

DAILY CHECK LIST

- 1) Always wear relatively tight and belted clothing to avoid entanglement in moving parts. Wear sturdy, rough soled work shoes. Never operate tractor or implements in bare feet, sandals or sneakers. Ensure other required PPE is in good condition.
- 2) Ensure all safety shielding is properly installed and check that all nuts and bolts are secure and pins are properly cotter pinned.
- 3) Check condition of blades and security of attachment.
- 4) Ensure mower is properly connected to the tractor, adjusted and in good operating condition.
- 5) Tall grass can hide obstacles. Carefully walk the entire area to be mowed beforehand. Look for debris, rocks, tree limbs etc. that will damage or be thrown by the mower blades. Identify objects that cannot be removed. Set mower cutting height to avoid contact.
- 6) Never permit any person other than the operator to ride or board the tractor at any time.
- 7) Check that all lubrication points with grease fittings have been lubricated as per schedule.
- 8) Check the gearbox for possible oil leaks.
- 9) Be sure wing release pull rope and hydraulic hoses are properly secured and will not become entangled in PTO shaft.
- 10) Ensure deck lock system is functioning properly (Page 26).

DECK LOCK SYSTEM

The deck lock system on the TDR-26 mower is a multi-function system controlled by the pull rope

Deck lock plates are activated by the pull rope and engage with the mower wings / rear lift arm in different positions to provide a variety of functions:

As with any mechanical system, the lock system needs to be used and maintained properly. With only a few moving parts, this is a simple task.

In a safe level location, fully lower the decks to the ground, shut the tractor engine off, and set the parking brake.

With the lock rope released, all three lock plates should lay flat against the wing frames. This is critical for proper function of the Pro Lift-N-Turn™ system (Page 29)

Check each of the three lock plates and make sure they do not bind when the lock release rope is pulled or released.

Ensure that the lock plate, cables and springs are in good condition.

Check to see if the center lock swivel is free to rotate without binding and returns to a neutral position so that the cables have slack when the lock plates are lying flat against the wing frame.

If any binding or damage is found, repair the issue before proceeding to use the mower

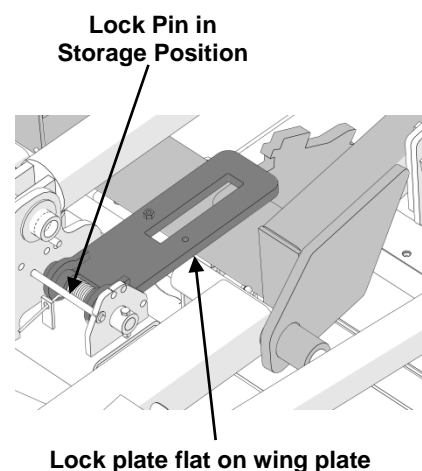

TRANSPORT LOCK

When the decks are in the fully raised position, the lock plates engage with each wing and the rear lift to ensure they do not lower when hydraulic pressure is relieved.

The lock stop pin must be in the position shown when transporting the mower.

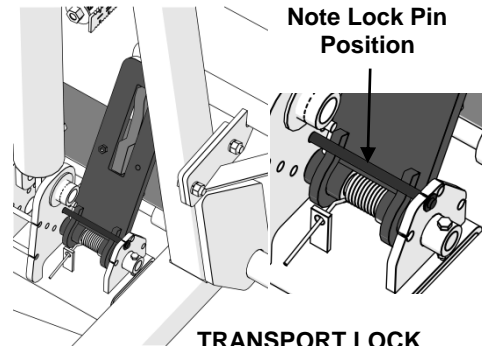

TRANSPORT LOCK POSITION - WINGS

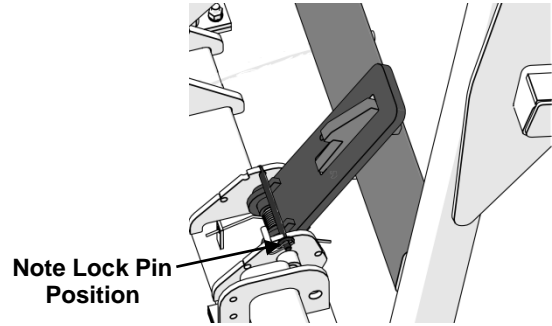

TRANSPORT LOCK POSITION - REAR

WASH-DOWN POSITION

In order to facilitate cleaning the bottoms of the mower decks, a lock position is provided to support the wings at mid-travel.

This position is present on the wings only; the rear deck will be raised to transport position for washing.

Ensure the lock pin is in the position shown when using this function.

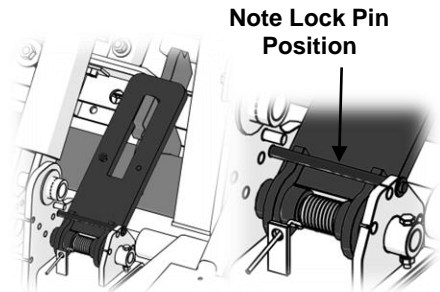

WASH-DOWN POSITION

! WARNING!

Never stand beneath the mower decks when placed in the wash-down position.



PRO LIFT-N-TURN™ – See Page 29

If it is not desired to use the Pro Lift-N-Turn™ system, it is possible to disable it by inserting the lock pin in the position shown in the accompanying illustration.

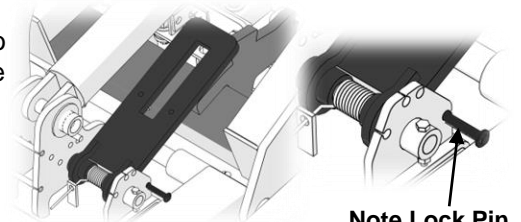

PRO LIFT-N-TURN™ DISABLED

RAISING AND LOWERING THE DECKS

The mower decks are raised into transport position by the hydraulic cylinders via the tractor control valve.

To raise the decks from the mowing position, pull the pull rope and hold. Engage the tractor hydraulic control to raise the decks. In order to avoid the Pro Lift-N-Turn™ position, the rope must remain pulled while the decks are raised. Release the pull rope when fully raised.

When the decks are fully raised, ensure that the wing and rear deck locks are properly engaged before proceeding. If there is a problem with the lock engagement, lower the decks to the ground before investigating any problems.

For transporting the mower, move the lock pins in to the "Transport" position (See page 26).

To lower the decks from the transport position, pull the pull rope to disengage the transport locks and lower the decks to the ground using the tractor hydraulic control. To avoid the wash-down lock position, the rope must remain pulled until the decks reach the ground.

It is normal for the decks to settle against the locks during storage or transport. It may be necessary to raise the decks in order to disengage the locks

ADJUSTING THE CUTTING HEIGHT

Each of the three independent mower decks has its own cutting height adjustment. Cutting height is set via an easy to use jack screw system on each corner of the deck. A combination 1 1/2" wrench / 15/16" socket tool is provided with the machine to perform these adjustments.

NOTE: For optimal cutting results, the mower should be set to remove not more than 1/3 of the total grass height. This will result in the best cutting performance while minimizing stress to the grass.

To make a height adjustment, follow these steps:

- 1) Lower the decks to mowing position.
- 2) Loosen the (2) 15/16" locking nuts on the side channel
- 3) Loosen the (2) 1 1/2" jam nuts
- 4) Turn the 15/16" nut on top of each adjusting screw to desired height displayed on the height indicator plate. Ensure the reading is the same on both ends of the side channel.
- 5) Tighten jam nuts
- 6) Tighten the sided channel locking nuts
- 7) Repeat steps 1-6 for each side channel on the mower (6 total)

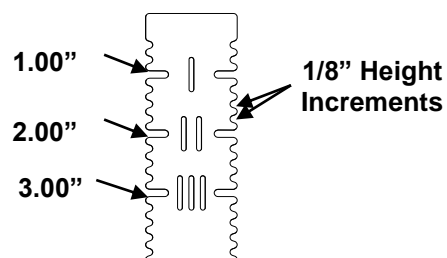

Cutting Height Scale

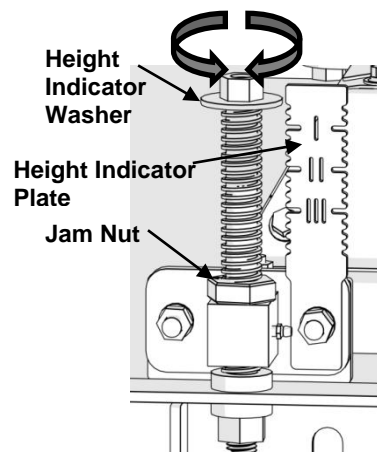
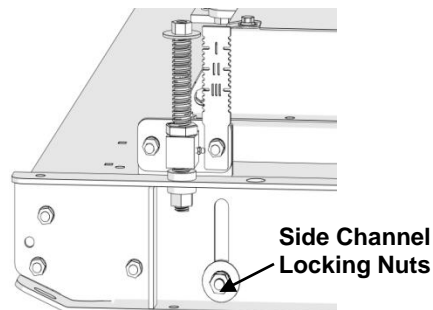

ENGAGING THE MOWER

When engaging the mower, it is important to follow this procedure:

- 1) Lower the decks into the working position.
- 2) Raise decks to Pro Lift-N-Turn™ position (Page 29).
- 3) Set the tractor engine speed at 1000 rpm maximum.
- 4) Ensure that everyone is clear of the mower.
- 5) Engage the tractor PTO clutch.
- 6) Lower the decks into the working position and place tractor hydraulics in float position.
- 7) Select the proper ground speed gear and slowly engage the tractor ground drive.
- 8) Once the mower has come up to speed, slowly increase the tractor throttle to desired rpm.

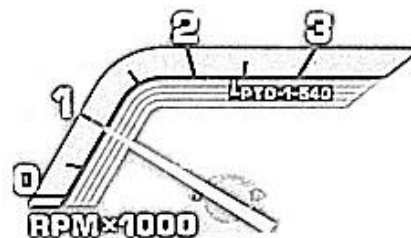

MOWING

The TDR-26 mower is a very versatile cutting machine that allows the operator to maintain turf on undulating terrain in a productive manner. Drive safely, cut safely. Be sure to idle the tractor back before engaging the PTO and shut the tractor off before leaving the tractor.

NOTE: Under normal cutting conditions, it may be desirable to operate the tractor at less than 540 rpm PTO speed, reducing fuel consumption and the noise level. Select a suitable ground speed gear to maintain proper cutting.

OPERATING ON HILLY TERRAIN

When operating on hilly terrain, proceed with caution and drive carefully. If the tractor has four-wheel drive, make sure it is engaged. On two-wheel drive tractors equipped with a differential lock, apply while driving straight on the hill, disengage to allow for normal turning.



WARNING!

Use care while turning on hillsides in wet conditions. The weight of the mower behind the tractor may push the tractor unexpectedly.

PRO LIFT-N-TURN™ OPERATION

The industry exclusive Pro Lift-N-Turn™ system found on the TDR-26 mower offers a real productivity advantage and it is a feature not offered on competitive mowers.

The Pro Lift-N-Turn™ system allows for the decks to be raised slightly off the ground with the PTO still engaged. This makes turns at the end of the pass easier and less stressful on both the turf and the equipment.

The function of this system is integrated in the deck safety lock system. As you approach a turn, raise the decks using the tractor hydraulic control (do not pull rope). A mechanical stop in the deck lock will limit the height of the deck rise. When the turn is complete, lower the decks to the mowing position, and engage the float for the hydraulic port in use.

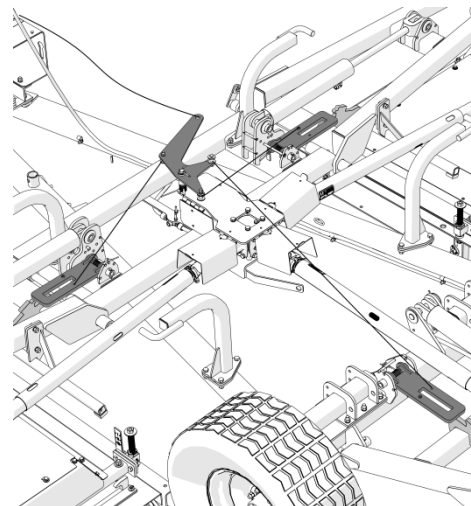

Operators must check the operation of the Pro Lift-N-Turn™ system prior to the start of each shift. Ensure that each latch plate is in the fully lowered (flat) position before starting to mow.

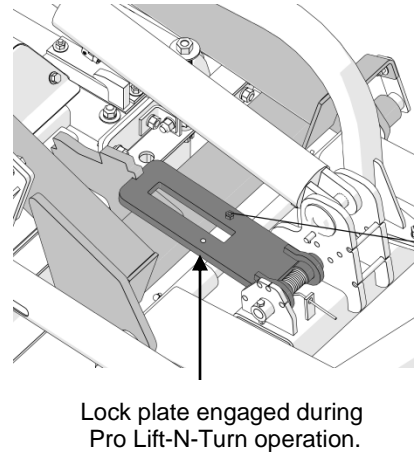
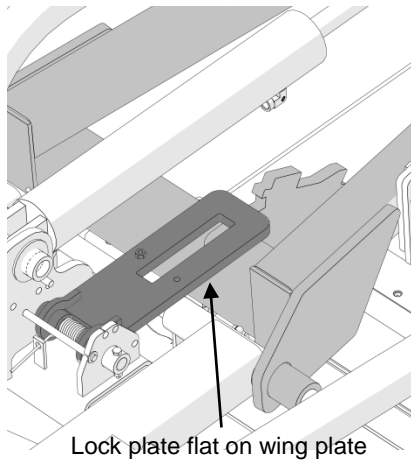

CAUTION!

If the Pro Lift-N-Turn™ system is actuated with the PTO running, and any of the latch plates are not in the correct position, the Pro Lift-N-Turn™ system cannot prevent that deck from rising too far. **Damage to the PTO drive will result.** It is the responsibility of the Operator to ensure the Pro Lift-N-Turn™ system is functioning properly before use.

TRANSPORTING THE MOWER

When transporting the TDR-26 from site to site, ensure the wings are in the raised position and deck safety locks are engaged (Page 26). Ensure the transport safety chain is properly fastened to the tractor (Page 21).

Ensure SMV placard is clean and all loose debris has been removed from the mower before transporting.

Observe the maximum allowable transport speed dependent on towing vehicle weight:

Towing Vehicle Weight	Maximum Allowable Road Speed
5820lb / 2640kg or more	up to 20 mph (32 km/h)
2910-5819lb / 1320 – 2639kg	up to 10 mph (16 km/h)

WARNING!

Use an appropriately sized vehicle to tow the TDR-26 mower. Do not tow with vehicles that are less than 2910lb / 1320kg, vehicle handling and braking characteristics will be diminished.

MAINTENANCE

WARNING!

Ensure the tractor controls are in the park position, the engine is turned off, the parking brake is engaged, and hydraulic pressure has been relieved before performing service or maintenance.

Always use personal protection devices such as protective glasses and face shields, protective shoes, gloves, hard hats, and ear protection when performing service or maintenance functions.

When completing a maintenance or service function, make sure all safety shields are installed before placing mower in service.

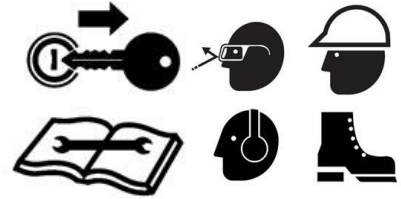

LUBRICATION

A properly maintained lubrication schedule will provide a smooth-running machine for many years. Some pivot locations have grease fittings. The following information shows and describes where lubrication points are located and what types of lubricant are required.

		Lubrication Intervals				
		Initial Run - 50h	Daily	As Req'd	100h / Monthly	600h / Yearly
Grease	Intermediate Hanger Bearing	-	X	-	-	-
	Deck Pivots	-	-	X	-	-
	Transport Wheels	-	-	X	-	-
	Wing Pivots	-	-	X	-	-
	Wing PTO Shaft (7 locn's each)	-	-	-	X	-
	Input PTO Shaft (7 locn's)	-	-	-	X	-
	Int. PTO Shaft (2 locn's)	-	-	-	X	-
Oil	Inspect Gearboxes	-	X	-	-	-
	Check Gearbox Oil	-	-	-	X	-
	Change Gearbox Oil	X	-	-	-	X

The TDR-26 blade spindles are factory equipped with maintenance free sealed bearings as original equipment. The blade spindles do not require manual greasing.

CAUTION!

Never direct high pressure water spray at the blade spindles (top or bottom). Water may enter the bearings and lead to premature failure.



GREASE SPECIFICATIONS

All greases are not compatible. Grease incompatibility will decrease the lubrication ability of the grease and can cause premature part failure.

Grease can have mineral or synthetic base oils and thickening agents such as lithium, calcium, barium, sodium, or aluminum

What We Use:

- Progressive uses Shell Gadus S2 V220 2
- This grease has:
 - A mineral oil base
 - A lithium-12 hydroxy thickener ("lithium" thickener)
 - Extreme Pressure additives (EP)
 - An NLGI Grade 2

Recommended Grease Properties

The grease you use for this machine must have these properties:

- NLGI grade 2
- Lithium thickener (NOT LITHIUM COMPLEX)¹
- Kinematic Viscosity at 40°C is no greater than 220 cSt
- Dropping Point Less than 400° F
- General Purpose Grease, Not Heavy Duty
- **No MOLY (molybdenum disulphide) additives in the grease²**
- **No synthetic grease³**
- **No High Temperature Grease⁴**

Notes on grease compatibility:

- 1) If a thickener other than lithium is used (including lithium complex), the existing grease will be contaminated, and the lubrication properties may be lost leading to component damage.
- 2) Molybdenum Disulfide (Moly) is an additive used in slow moving, extreme load applications. The particles in the "Moly" will actually increase bearing wear in a high-speed mower application. Generally speaking Moly based greases will be grey in colour.
- 3) If synthetic base oil is used rather than mineral base oil, the grease will be contaminated; the lubrication properties may be lost leading to component damage.
- 4) We do not recommend the use of "High Temperature" greases, mower component temperature should never reach temperatures above the level at which general purpose greases can operate. "High Temperature" greases may contain thickeners that are not compatible with Lithium-12 Hydroxy based thickeners.

Grease with these features is considered to be a "General Purpose Grease". Use on all grease point locations on your Progressive Mower. Check the properties of the grease you wish to use with your supplier prior to use.

CAUTION!

When performing daily greasing routine, ensure all grass clippings are removed from the mower decks. Clipping build-up can cause overheating of the bearings and belts leading to premature wear and subsequent failure.

INTERMEDIATE BEARING – 8h / Daily (1 Location)

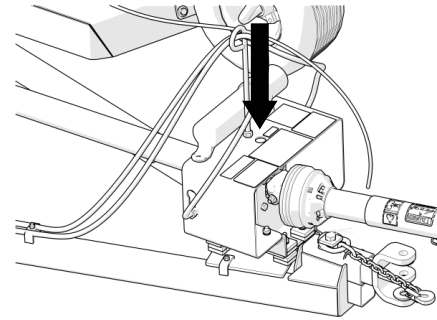

! CAUTION!

Use only manual pump-style grease guns for lubricating driveline components. Use of power greasing equipment can induce excessive pressure into the component, compromising sealing components and leading to premature wear and component failure.

DRIVELINE GREASING

Driveline shafts on the TDR-26 mower feature a 100 hour grease interval. The following decal located on the hose support shield as a reminder of the minimum requirement.

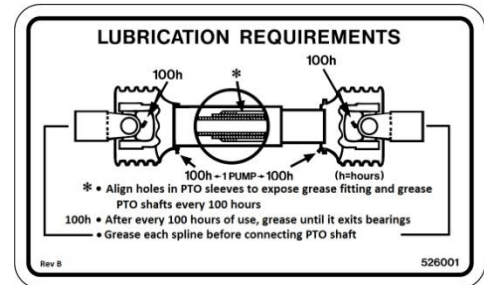

INPUT & DECK SHAFTS – 100h / Monthly (7 / Shaft - 4 Shafts)

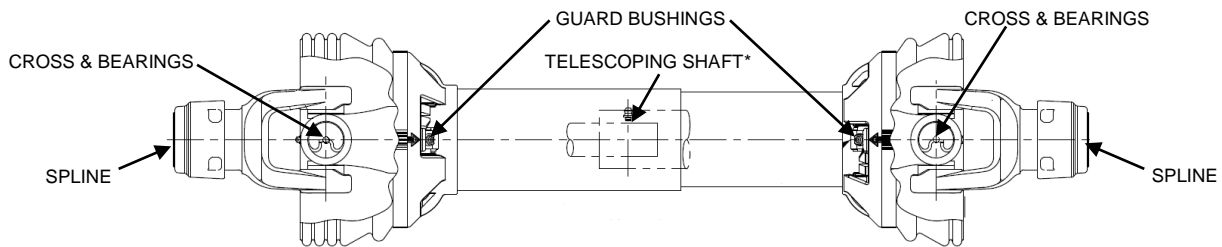

* Inner & outer guards must be rotated to align holes for accessing telescoping shaft grease fitting.

! CAUTION!

Failure to properly lubricate the telescoping shaft sections will lead to binding of the shaft and damage to the mower or tractor driveline.

INTERMEDIATE SHAFT – 100h / Monthly (3 Locations)

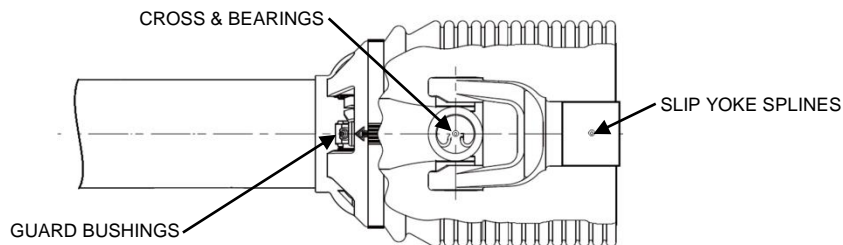

TRANSPORT HUBS & OTHER LOCATIONS: As Required

All pivot locations have grease fittings. These include the wing hinge pivots, the transport wheel hubs, the rotating hitch and the hitch clevis. Lubricate these areas per the recommended schedule

GEARBOX OIL:

Recommended Oil: SAE 90 EP or SAE 80W90 EP

Factory Fill: Shell Spirax HD SAE 80W90



MOWER MUST BE LEVEL when checking oil level

DO NOT OVERFILL! Gearbox may over-heat causing premature component damage.

DECK GEAR BOX

Checking Level – 100h / Monthly

A threaded dipstick is located on the top of the gearbox. Proper oil level is set when oil is between (2) lines on dipstick. Proper level is taken **without** threading dipstick into gearbox. If the level is low, add oil through dipstick port until correct level is attained. Replace and tighten dipstick.

Changing Oil - 600h / Yearly

The gearbox oil should be changed after the first 50 hours of operation and every 600 hours or yearly afterwards.

Oil change quantity – 1.37 Qt (1.3 Litres)

4-WAY GEAR BOX

Checking Level – 100h / Monthly

A screw-in dipstick is provided on the top of the gear box. Proper oil level is set when oil is between the marks on the dipstick. If the level is low, add oil through top plug until correct level is attained. Replace and tighten plug.

Changing Oil - 600h / Yearly

The gearbox oil should be changed after the first 50 hours of operation and every 600 hours or yearly afterwards.

Oil change quantity – 1.48 Qt (1.4 Litres)

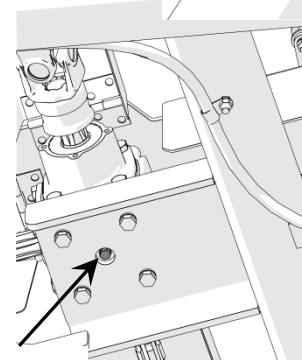
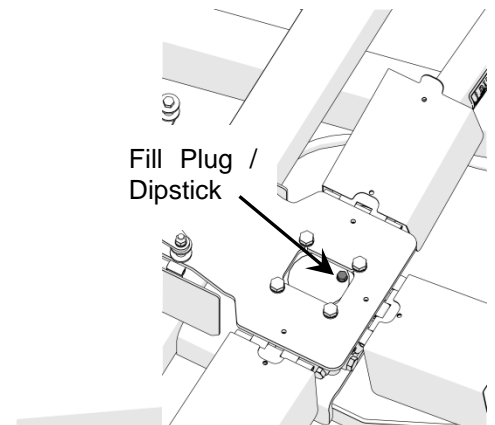
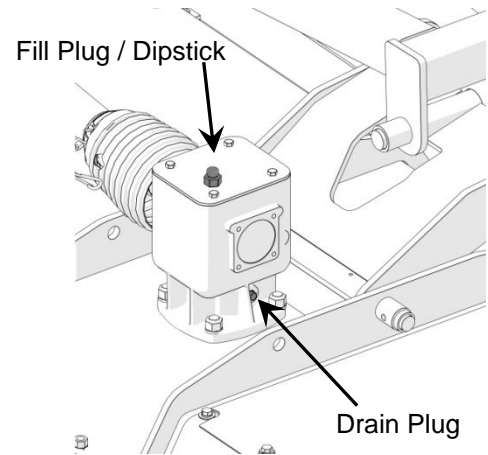

“V” BELT DRIVE

“V” BELT TENSION - 100h / Monthly

Proper belt tension is a fundamental factor in successful V-belt operation. Lack of tension will cause slippage, and too much tension will cause excessive belt stretch as well as damage to the drive components, such as bearings and shafts. To assess the condition of the automatic tensioner, the following procedure is recommended.

At the mid-point of the span (see illustration below), apply a deflection force with a spring scale in the direction perpendicular to the span until the belt is deflected the 3/8”.

The recommended force to deflect the belt is a minimum of 5 lbs. to a maximum of 7 lbs.

The first 24 to 48 hours of operation is the belt “run in” period. To ensure satisfactory belt performance, belt tension should be checked during this time period.

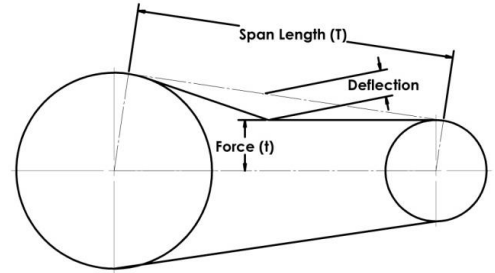

“V” BELT ADJUSTMENT

Each mower deck has (2) belts to transmit power from the gear box to the blade spindles. Each drive belt utilizes an adjustable sliding tensioner idler to set belt tension.

In the event that belt adjustment must be made, follow these steps for each belt:

- 9) Loosen the jam nut on the adjusting screw.
- 10) Loosen the nut fixing the tensioning idler to the mower deck.
- 11) Set desired belt tension by turning the adjusting nut
- 12) Clock Wise to tighten belts
- 13) Counter Clock Wise to loosen belts
- 14) Tighten the nut fastening the tensioning idler to the mower deck.
- 15) Tighten jam nut on the adjusting screw.
- 16) Verify proper tension is achieved per “V” Belt Tension section above.

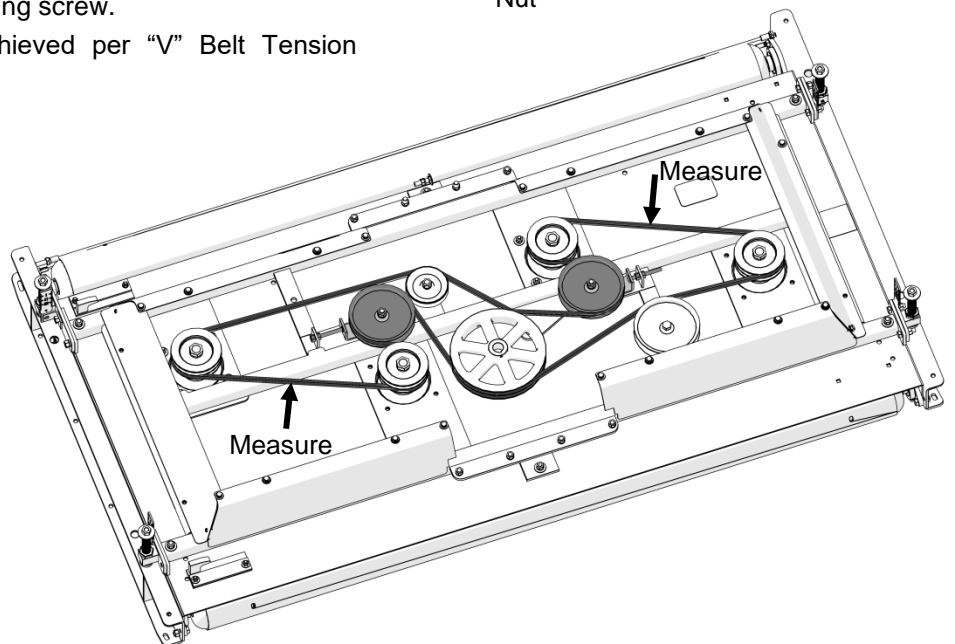
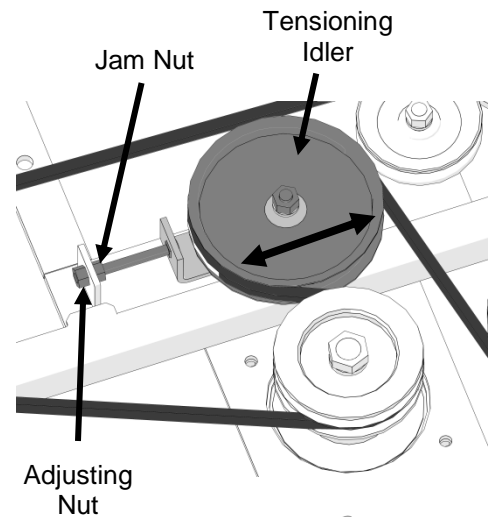

FASTENER INSTALLATION TORQUE

The chart below lists the proper installation torque for fasteners on Progressive Turf Equipment mowers. When bolts are to be tightened or replaced, refer to this chart to determine the proper torque (unless otherwise specified in this manual).

SAE Grade 5 fasteners are to be used in the assembly of this machine, unless otherwise specified in this manual.

Bolt Grade Identification

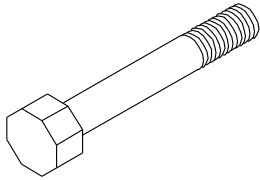

SAE Grade 2
(No Dashes)

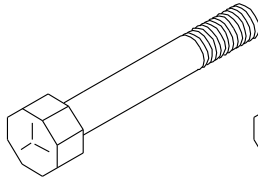

SAE Grade 5
(3 Dashes)

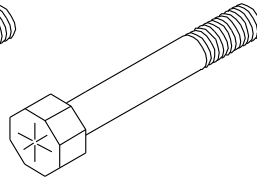

SAE Grade 8
(6 Dashes)

Bolt Diameter	Recommended Torque in Foot Pounds (Newton-Meters)
5/16 UNC	21 (28)
3/8 UNC	38 (52)
7/16 UNC	55 (75)
1/2 UNC	85 (115)
9/16 UNC	125 (170)
5/8 UNC	175 (240)
3/4 UNC	300 (410)
7/8 UNC	450 (610)
1 UNC	680 (925)
1-14 LH Spindle Nut	60 (82)
M12x1.5 (Note)	55 (75)
Pro-EZ Change Bolt	110 (150)

NOTE: 4-Way gearbox mounting bolts are M12

BLADE SERVICING

WARNING!

Always observe proper lock-out procedures when performing any maintenance work including changing or servicing the blades. Always remove and retain the ignition switch key, ensure parking brake is engaged, and block and or support machine using equipment designed for the task.

Be sure deck safety locks are engaged when working on decks in the raised position.

Use gloves when handling mower blades. Blades can be very sharp.

Inspect blades before each use to determine that they are mounted tightly and are in good condition. Replace any blade that is bent, excessively nicked, worn or has any other damage. Small nicks can be ground out when sharpening.



WARNING!

Use only original equipment blades when replacing worn or damaged mower blades. They are made of special steel alloys and subjected to rigid heat-treat and inspection requirements. Substitute blades may not meet these specifications and **MAY BE DANGEROUS.**



BLADE SELECTION

We offer four blade styles for use with this mower:

Fixed high lift

Combined with Progressive's high tip speed, the fixed High-Lift blade 'stands' grass blades up for a clean cut, even in damp conditions or at high mowing speeds.

Fixed low lift

Developing less lift than the High-Lift blade, Progressive's Low-Lift fixed blade is ideal for both new growth or sandy soils where abrasion is a concern but superior cut quality can never sacrificed. Also requires less tractor horse-power.

Pro-EZ Change System (Available in high or low lift)

Developed with turf professionals in mind:

- Economical as only the tips are changed
- Flat profile fastener extends life, reduces cost
- Standard hand-tools are used for reduced cost and easy change out
- Lower start-up torque requirement reduces stress on the complete drive train
- Thinner profile than a standard blade means the tips retain their sharpness after the equivalent number of mowing hours

Pro-Ez Change Blade System installs on the same blade support bar as a fixed blade. This allows users to easily swap blade types as growing conditions or mowing requirements change.

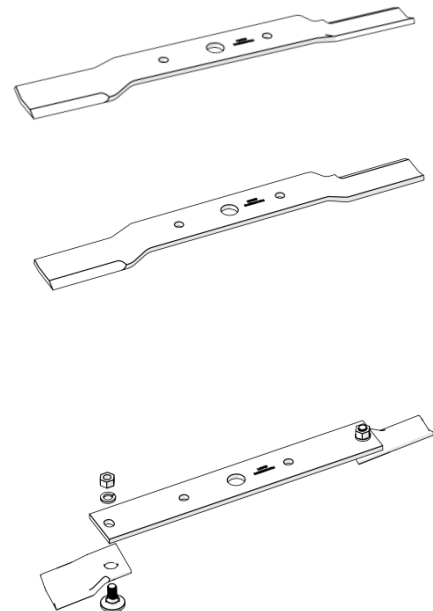

FIXED BLADE REMOVAL AND INSTALLATION

A 1" diameter pilot centers the blade on the spindle with two 1/2" grade 5 fasteners. When changing blades, be sure that pilot is properly seated in the blade and the blade lies flat on the spindle bar.

Always replace bolts, lock washers and nuts when replacing blades. Tighten bolts to proper torque as listed on Page 36.

Replace any blade that is bent, nicked deeper than 1/4", excessively worn or has any other damage. Small nicks can be ground out during sharpening. Always balance blades before use.

In abrasive soil conditions, monitor condition of the blade wing. If erosion of the steel is evident at the base of the wing, replace blade.

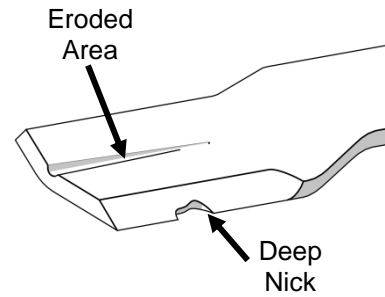

WARNING

TO AVOID SERIOUS INJURY OR DEATH FROM BLADE ATTACHMENT FAILURE
CHECK THE FOLLOWING COMPONENTS BEFORE OPERATING EQUIPMENT:

<ul style="list-style-type: none"> • Check mounting bolts DAILY for tightness • Torque mounting bolts to 85 ft.-lb. • ALWAYS replace bolts, lock washers and nuts when replacing blades or blade bars 	<p style="text-align: center;">Optional Pro-EZ Change Blades</p> <ul style="list-style-type: none"> • Check blade tip bolts DAILY for tightness • Torque blade tip bolts to 110 ft.-lb. • ALWAYS replace nuts and lock washers when replacing blade tips
--	---

209193

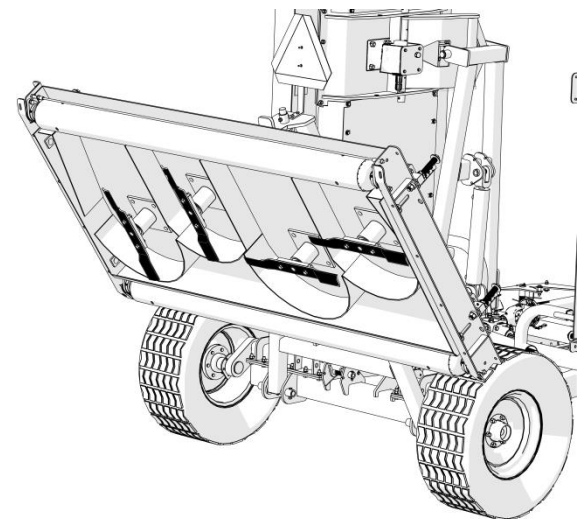

Pro-EZ CHANGE BLADE REMOVAL AND INSTALLATION

Blade Bar

A 1" diameter pilot centers the blade bar on the spindle with two 1/2" grade 5 fasteners. When changing blades, be sure that pilot is properly seated in the blade bar and the blade bar lies flat on the spindle.

Always replace bolts, lock washers and nuts when replacing blade bars. Tighten bolts to proper torque as listed on Page 36.

Replace any blade bar that is bent, worn or has any other damage.

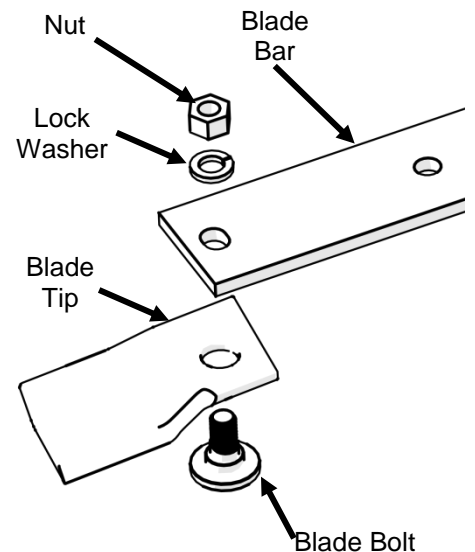

Blade Tip

The Pro-EZ change blade tips are serviceable with a single wrench. An anti-rotation slot engaging the blade bolt to the blade bar allows for installation and removal of the nut from one side without having to hold the bolt.

When removing blade tips, inspect the tips and blade bolts for wear and damage.

Replace any tip that is bent, nicked deeper than 1/4", excessively worn or has any other damage. Small nicks can be ground out during sharpening. Always balance Pro-EZ blades as an assembled unit.

Replace any blade bolts that have the head or blade shank worn beyond the limits shown in the accompanying illustrations.

Always install new blade bolts, lock washers and nuts when installing new blade tips. Tighten bolts to proper torque as listed on Page 36. **DO NOT OPERATE WITH ONLY ONE BLADE TIP INSTALLED.**

Grass build-up between the tip and blade bar may prevent the tip from pivoting properly at start-up or during mowing. Ensure all tips are free to rotate prior to operation.

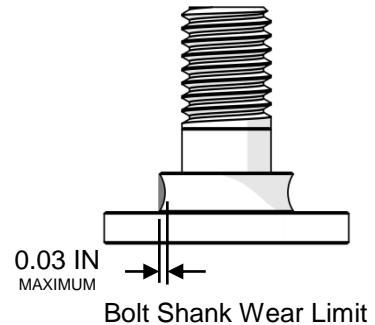
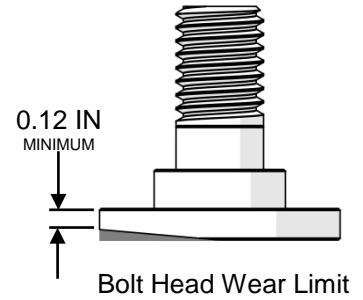

BLADE SHARPENING



Use gloves when handling mower blades. Blades can be very sharp.

When sharpening blades, be sure material removed is equal on both sides of the blade. Unbalanced blades will cause excessive vibration leading to cracks in machine components.

- Clean all material from the blade prior to sharpening and balancing.
- Grind or file blades following original pattern as shown.
- Sharpen to a razor edge. Do not sharpen back side of blade.

Use the supplied cone balancer (pn 209000) to verify blade balance. When the blade is correctly balanced, the blade will remain horizontal.



Failure to properly balance blades after sharpening can cause vibration leading to premature component damage. Pro-EZ Change blades must be balanced as a complete assembly (blade bar, blade tips & blade tip hardware).



Wear appropriate eye and face protection when sharpening blades.



Maintain Corners

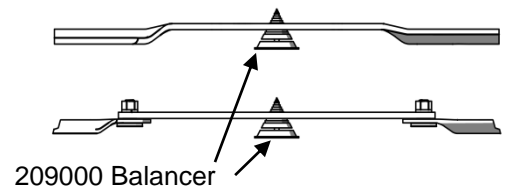
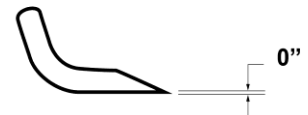
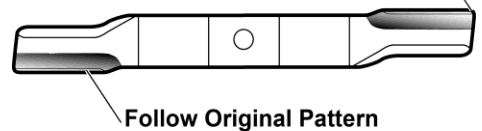

SPINDLE SERVICE

Each spindle is supported by two ball bearings. No adjustment of clearance is required. Running clearance is pre-set during assembly by tightening the 1" NF left hand nut on top of the pulley.

Periodically inspect blade spindles by grasping pulley, and moving from side to side. If any free play is noted, replace or repair.

SPINDLE ASSEMBLY REMOVAL

- 17) With the mower decks in the transport position, remove the blade.
 - 1) Lower decks to mowing position.
 - 2) Relieve belt tension and remove belt from the spindle pulley.
 - 3) Place a piece of cardboard or other soft material on the ground beneath the spindle to be removed.
 - 4) From above the deck, loosen & remove the four nuts that hold the spindle assembly to the deck. The spindle assembly will drop on to the ground.
 - 5) Remove the complete spindle assembly from beneath the deck.

SPINDLE ASSEMBLY INSTALLATION

Reverse above procedure. Be sure spindle mounting area of deck is clean of any foreign material before attaching spindle assembly.



Never direct high pressure water spray at the blade spindles (top or bottom). Water may enter the bearings, compromise lubrication and lead to premature failure.



SPINDLE ASSEMBLY REPAIR

Note: A video showing this rebuild procedure is available on our website: <http://www.progressiveturfequip.com/service>



Spindle repair requires special skills and tools, a shop press is required. If your shop is not properly equipped or your mechanics are not properly trained in this type of repair, complete spindle assemblies are available as service parts.

- 18) Remove LH Nut (1), lock washer (2), pulley (3), and spacer (5) from spindle assembly. **The spindle nut is left-hand thread.**



Make sure that the press ram and bed 100% square to each other. If bearings are not square in housing, bearings will wear out prematurely.

- 19) Place assembly in shop press with support under spindle housing flange and press spindle down through housing.

- 20) Remove bottom bearing from spindle and top bearing from housing

IMPORTANT! Removing bearings from spindle / housing causes permanent damage to the bearings. New bearing must be used in re-assembling the spindle.

- 21) Inspect bearing (8) spacer for wear. If any wear is present, replace spacer with new.

IMPORTANT! Failure to replace a worn or damaged spacer will lead to premature top bearing wear.

- 22) Place housing (7) in press (upside down). **Pressing on outer race**; install bottom bearing (9) into housing.

- 23) Place spindle (12) in press. Place dirt shield (11) and shim (10) on spindle.

- 24) **Pressing on inner race** of bottom bearing, press housing / bearing on to spindle. A steel tube will be required to slide over the spindle and press on inner race.

- 25) Install bearing spacer (8) with hole end up.

- 26) Set top bearing (6) on to spindle. **Pressing on inner race**, press top bearing on to spindle (may be a loose fit in housing).

- 27) Install shim washer (5), key (4) and pulley (3) on to spindle.

- 28) Install lock washer (2) and nut (1) and torque to 60 ft-lb.

Rotate the housing six revolutions by hand to check for free movement.

The assembly is now ready for installation into the mower deck.

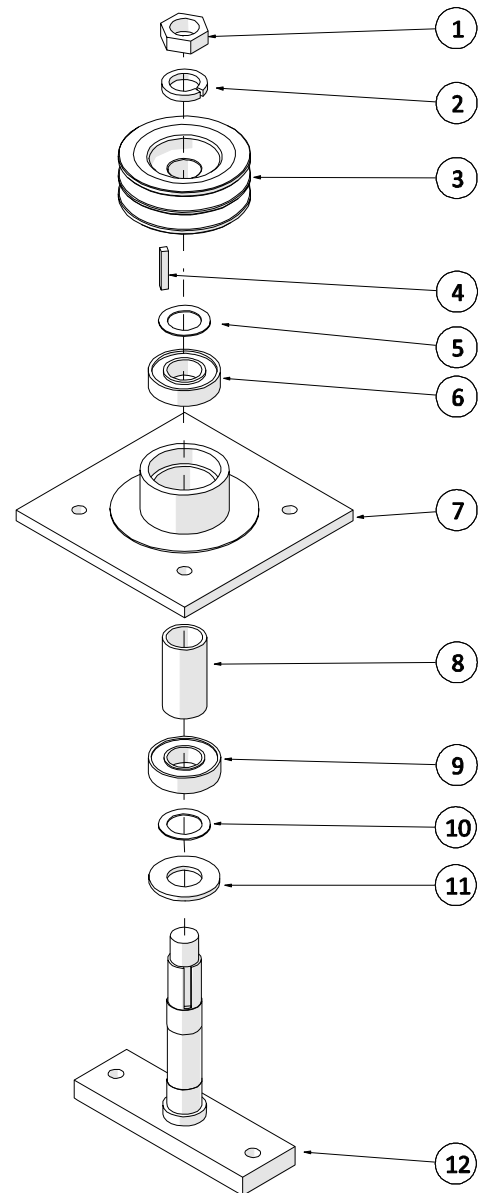

HYDRAULICS

WARNING!

Do not use your hand to check for hydraulic oil leaks. Use a piece of cardboard instead.

Hydraulic fluid escaping under pressure can penetrate the skin causing serious injury. If skin penetration occurs, seek medical attention immediately.

Relieve all pressure from hydraulic system before disconnecting hoses.

During your daily inspection repair all leaks before they create a major problem. Relieve all pressure before working on, or disconnecting the line in the hydraulic system.

The hydraulic system on the TDR-26 mower is a simple cylinder system used to raise and lower the cutting decks into position. Each cylinder is equipped with a .032 diameter restrictor orifice in the rod-end elbow adapter to throttle the speed of travel.

When reconnecting to the tractor, be sure that both connector ends are clean. Dirt in the hydraulic system can block the orifice in the line throttle valve or cause premature wear & failure of hydraulic components on the mower or tractor.

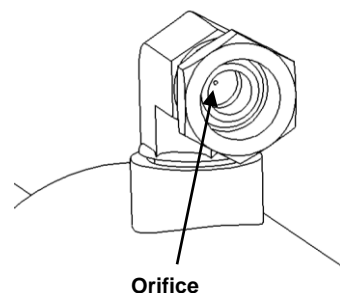

SUPPORTING MACHINE FOR SERVICE

(2) Points are available to lift the mower off of the ground for servicing the transport tires / wheels / bearings at the main frame rail just in front of the transport tires (as shown in the accompanying illustration.) Use a bottle or service jack to raise the wheel from the ground and place a jack stand, wooden block or other suitable support under the rectangular tube.

WARNING!

Do not support the machine on cinder blocks, hollow tiles or other members that may fail under continuous load.

Never perform service on a machine that is supported solely by a jack. Always ensure proper blocking is placed to support load during service.

If the transport tires must be changed with the wings in the raised position, ensure the machine is on a flat, level surface and the wing locks are fully engaged before attempting to lift the machine.

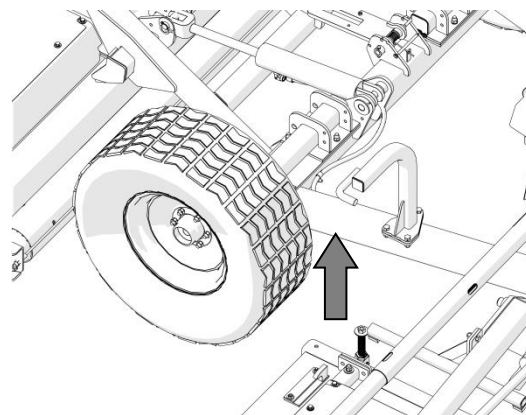

TRANSPORT TIRES

Inspect tires daily for wear or damage. Check tire pressures weekly with an accurate pressure gauge. Do not inflate tires beyond 35 psi.

WARNING!

Mounting and dismounting tires from rims can be dangerous and should be performed by trained personnel using correct tools, equipment and procedures.

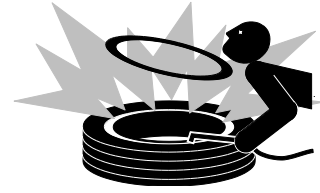

LONG-TERM STORAGE

If the mower is not to be used for an extended period of time (4 months or longer) it is recommended that the following maintenance steps are followed:

- 1) Thoroughly wash mower, removing all grass clipping residue from deck undersides & mower framework. Ensure deck drain holes are free from debris.
- 2) Add grease to all grease points.
- 3) Check gearbox oil for proper level.
- 4) Relieve tension on all V-belts.
- 5) Inspect all drive belts & pulleys.
- 6) Inspect all blade spindle bearings for excessive play and smooth operation.
- 7) Inspect all blades for serviceable condition.

When returning the mower to service after long-term storage:

- 1) Check tightness of all blade fasteners.
- 2) Add grease to all grease points.
- 3) Set tension on all V-belts.
- 4) Ensure all pivot points move freely.
- 5) Change gearbox oil.

TROUBLESHOOTING

PROBLEM	CAUSE	REMEDY
Uneven Cutting	Improper Height Setting	Ensure that cutting height is set properly at all 4 corners of each deck (Page 28)
	Damaged Blades	Inspect blades for damage, replace as required
Belt slippage / Squeal	Lack of tension	Inspect & adjust tension as required (Page 35)
	Over Loading	Increase cutting height or reduce ground speed
Rapid belt wear	Belt slippage	See Above
	Belt not aligned properly	Check belt alignment. Ensure belts are running in proper groove on pulley.
	Over heating	Ensure decks are free from clipping build-up
Over-heated bearings	Belt slippage	See Above
	Insufficient Cooling	Ensure decks are free from clipping build-up
Premature spindle bearing failure	Over-heating	See Above
	Improper rebuild procedure	See specific instructions in manual (Page 40)
	Improper bearings	Use only OEM bearings
	Water Ingress	-Avoid direct spray on bearing during washing -Ensure drain holes on decks are not clogged
Deck safety locks will not engage	Wing not raising fully to release lock	Decrease center distance (retracted length) of cylinder with adjustable clevis on cylinder rod
	Binding in lock mechanism	Check all lock pivots to ensure free operation. Clean and lubricate as required.
Mower Deck will not lower.	Orifice in cylinder plugged	Remove orifice and remove obstruction and reassemble (Page 42)
Vibration on turning	Drawbar length incorrect.	Adjust drawbar to specification (see Page 21)
Damaged intermediate bearing or tractor PTO shaft	Input shaft does not collapse easily under power	Remove input shaft, pull apart and deburr / grease splines (Page 31) Grease at proper interval

Parts List

TDR-26



Effective serial number:
1826101 and up.

P.N. 120593

Issue Date: February, 2019

 **DANGER!**

Si No Lee Ingles, Pida Ayuda a Alguien Que Se Lo Lea
Para Que le Traduzca Las Medidas de Seguridad

Table of Contents

SERIAL NUMBER LOCATION.....	I
1 DECK ASSEMBLY	1
1.1 BLADE SPINDLE ASSEMBLY.....	1
1.2 BLADE OPTIONS	2
1.3 WING DECK GEAR BOX MOUNT.....	3
1.4 REAR DECK GEAR BOX MOUNT ASSEMBLY	4
1.5 WING DECK ASSEMBLY.....	5
1.6 WING DECK SHIELDS	6
1.7 WING DECK DRIVE.....	7
1.8 REAR DECK ASSEMBLY	8
1.9 REAR DECK SHIELDS	9
1.10 REAR DECK DRIVE.....	10
2 FRAME ASSEMBLY	11
2.1 FRAME ASSEMBLY.....	11
2.2 WING LOCKS.....	12
2.3 WING ASSEMBLY	13
2.4 REAR LIFT ASSEMBLY.....	14
2.5 WHEEL ASSEMBLIES	15
3 HYDRAULICS	16
3.1 HYDRAULICS	16
4 DRIVELINE.....	17
4.1 DRIVELINE	17
4.2 DECK PTO SHAFT	18
4.3 INTERMEDIATE PTO SHAFT.....	19
4.4 INPUT PTO SHAFT	20
4.5 DECK GEARBOX.....	21
4.6 4-WAY GEAR BOX.....	22
5 DECALS	23
5.1 SAFETY	23
5.2 NOTES.....	25

Serial Number Location

The serial number plate for the machine is located on the left side of the main frame tube at the front of the machine.

For quick reference, record the following information:

Model: _____

Serial Number: _____

Date purchased: _____

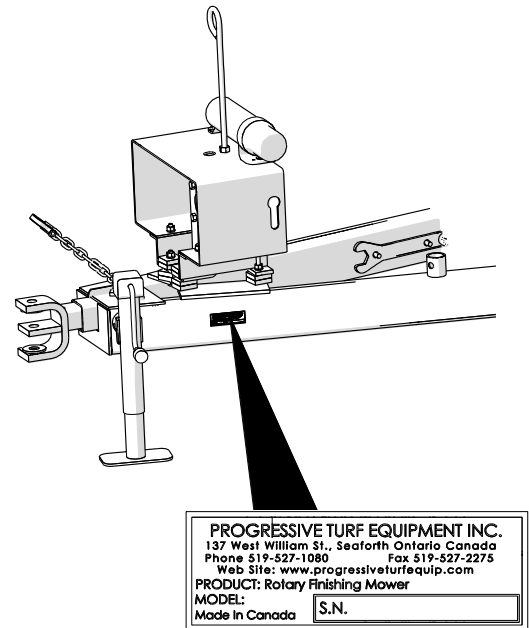

Always state this information when contacting your selling dealer and when ordering spare parts.

Parts Information

Use only Genuine Original Equipment Manufacturers (O.E.M.) replacement parts. The use of "will fit" parts may reduce machine performance, void machine warranties and present a safety hazard. Use Genuine OEM parts.

Progressive Turf Equipment Inc.

137 West William Street
 Seaforth, Ontario
 Canada
 N0K 1W0

Phone: 800-668-8873

Fax: 519-527-2275

www.progressiveturfequip.com

Maintenance

Maintenance should always be performed by a qualified service technician familiar with servicing similar equipment, using good safety and workmanship practices.

Always observe proper lock-out procedures when performing any maintenance work. Other than maintaining the blade spindles or blades, always lower all decks before performing maintenance. Block and or support machine using equipment designed for the task. When maintaining blades or spindles, always ensure locks are seated correctly in place. When performing hydraulic maintenance, ensure that pressure has been released.

It is imperative that the operator or qualified service technician reads and understands all the safety information in the Operator's Manual before proceeding. Failure to follow the instructions or heed the warnings could result in injury or death. **Proper care is your responsibility.**

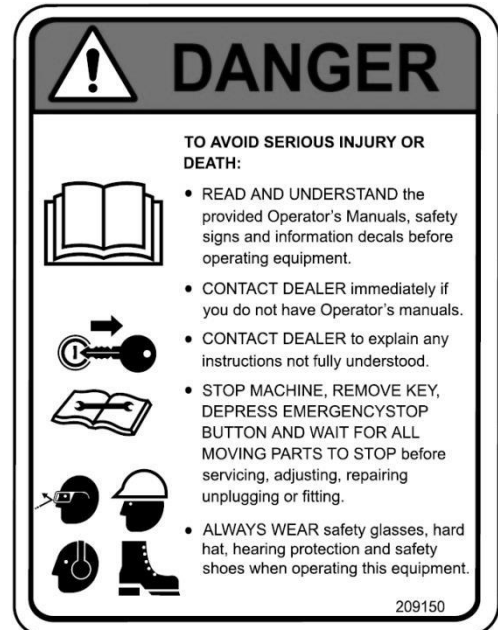

PARTS ORDERING GUIDE

The following instructions are offered to help eliminate needless delay and error in processing purchase orders for the equipment in this manual.

1. The Parts Section is prepared in logical sequence and grouping of parts that belong to the basic machine featured in this manual. Part Numbers and Descriptions are given to help locate the parts and quantities required.
2. The Purchase Order must indicate the Name and Address of the person or organization ordering the parts, who should be charged, and if possible the serial number of the machine for which the parts are being ordered.
3. The purchase order must clearly list the quantity of each part, the complete and correct part number, and the basic name of the part.
4. The manufacturer reserves the right to substitute parts where applicable.
5. Some parts may be unlisted items which are special production items not normally stocked and are subject to special handling. Request a quotation for such parts before sending purchase order.
6. The manufacturer reserves the right to change prices without notice.



1 DECK ASSEMBLY

1.1 Blade Spindle Assembly

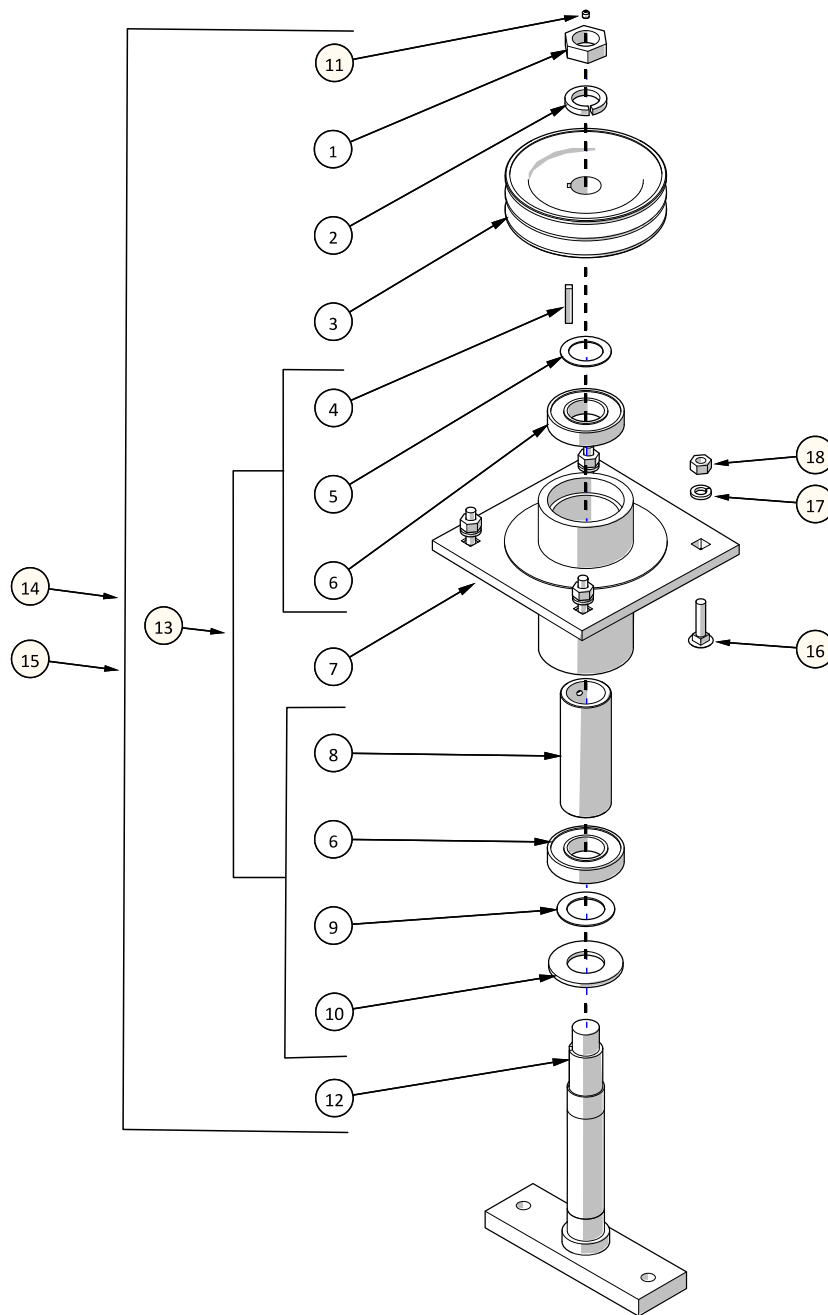

ITEM	PART #	DESCRIPTION	QTY
1	521003	HEX NUT- L.H.	1
2	521002	LOCK WASHER L.H., (3PCS)	1
3	521775	PULLEY - 5.9"	1
4	-	SPINDLE KEY	1
5	-	SHIM WASHER	1
6	-	BEARING	2
7	526092	SPINDLE HOUSING	1
8	-	BEARING SPACER TUBE	1
9	-	SHIM WASHER	1
10	-	DIRT SHIELD	1

ITEM	PART #	DESCRIPTION	QTY
11	O.L.	SET SCREW - 1/4"-28 X 1/4"	1
12	526098	BLADE SPINDLE	1
13	526980	SPINDLE REBUILD KIT	1
14	526748	BLADE SPINDLE - COMPLETE	1
15	526750	BLADE SPINDLE - LESS PULLEY	1
16	O.L.	CARR. BOLT- 7/16" X 1.75 NC GR5 PL	4
17	O.L.	LOCK WASHER- 7/16" PL	4
18	O.L.	HEX NUT - 7/16"NC GR5 PL	4

O.L. - OBTAIN LOCALLY

1.2 Blade Options

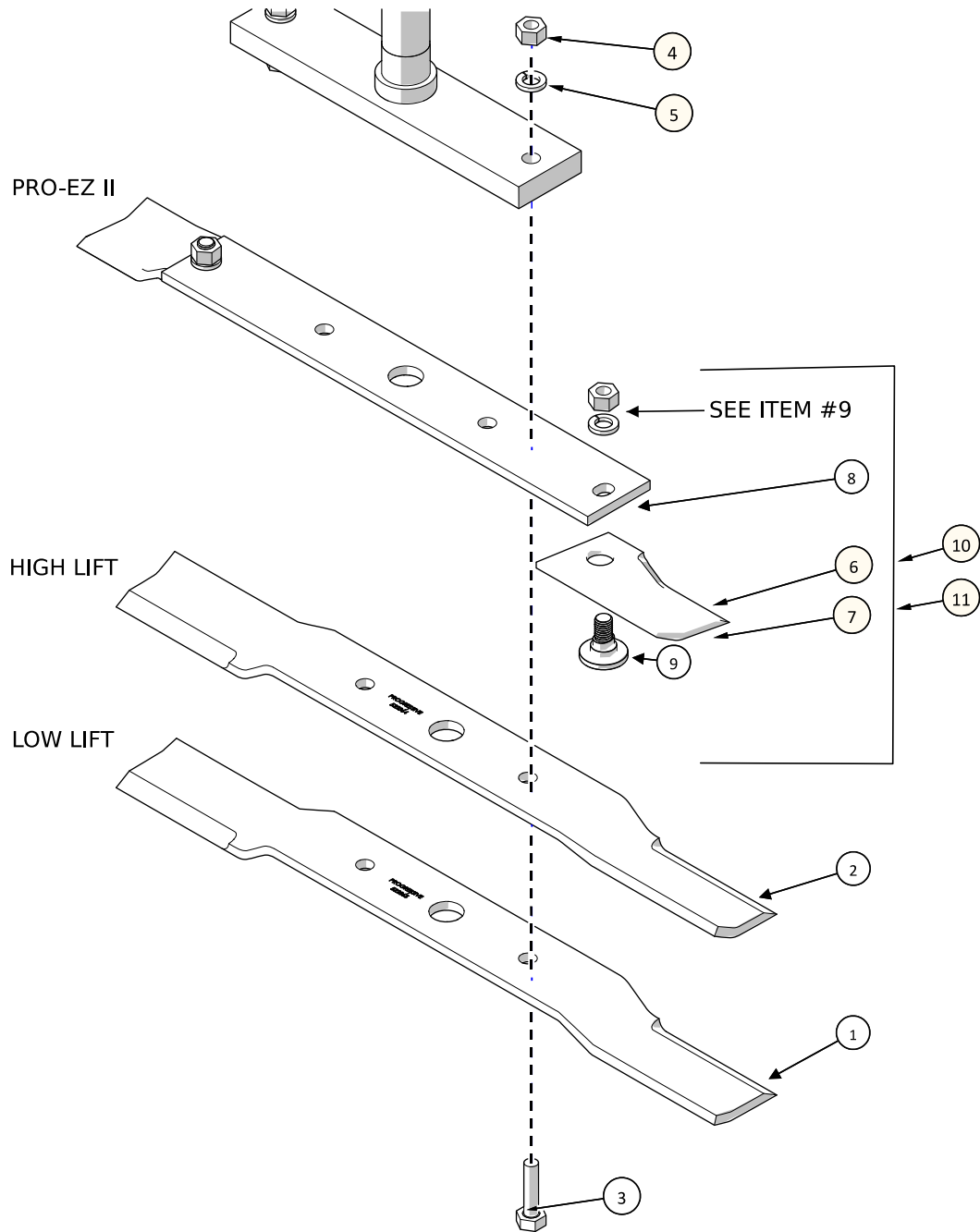

ITEM	PART #	DESCRIPTION	QTY
1	522618	LOW LIFT BLADE KIT (6 PCS)	1
2	522610	HIGH LIFT BLADE KIT (6 PCS)	1
3	O.L.	HEX BOLT- 1/2" X 1.75 NC GR5 PL	2
4	O.L.	HEX NUT - 1/2"NC GR5 PL	4
5	O.L.	LOCK WASHER- 1/2 PL	4
6	526594	HIGH LIFT TIP KIT (50 PC)	1
7	526648	LOW LIFT TIP KIT (50 PC)	1
8	526784	BLADE BAR KIT (12 PCS)	1
9	526866	BLADE BOLT KIT W/HW (25 PC)	1
10	526790	SINGLE HIGH LIFT BLADE ASSEMBLY (FOR 1 SPINDLE)	1
11	526792	SINGLE LOW LIFT BLADE ASSEMBLY (FOR 1 SPINDLE)	1

O.L. - OBTAIN LOCALLY

1.3 Wing Deck Gear Box Mount

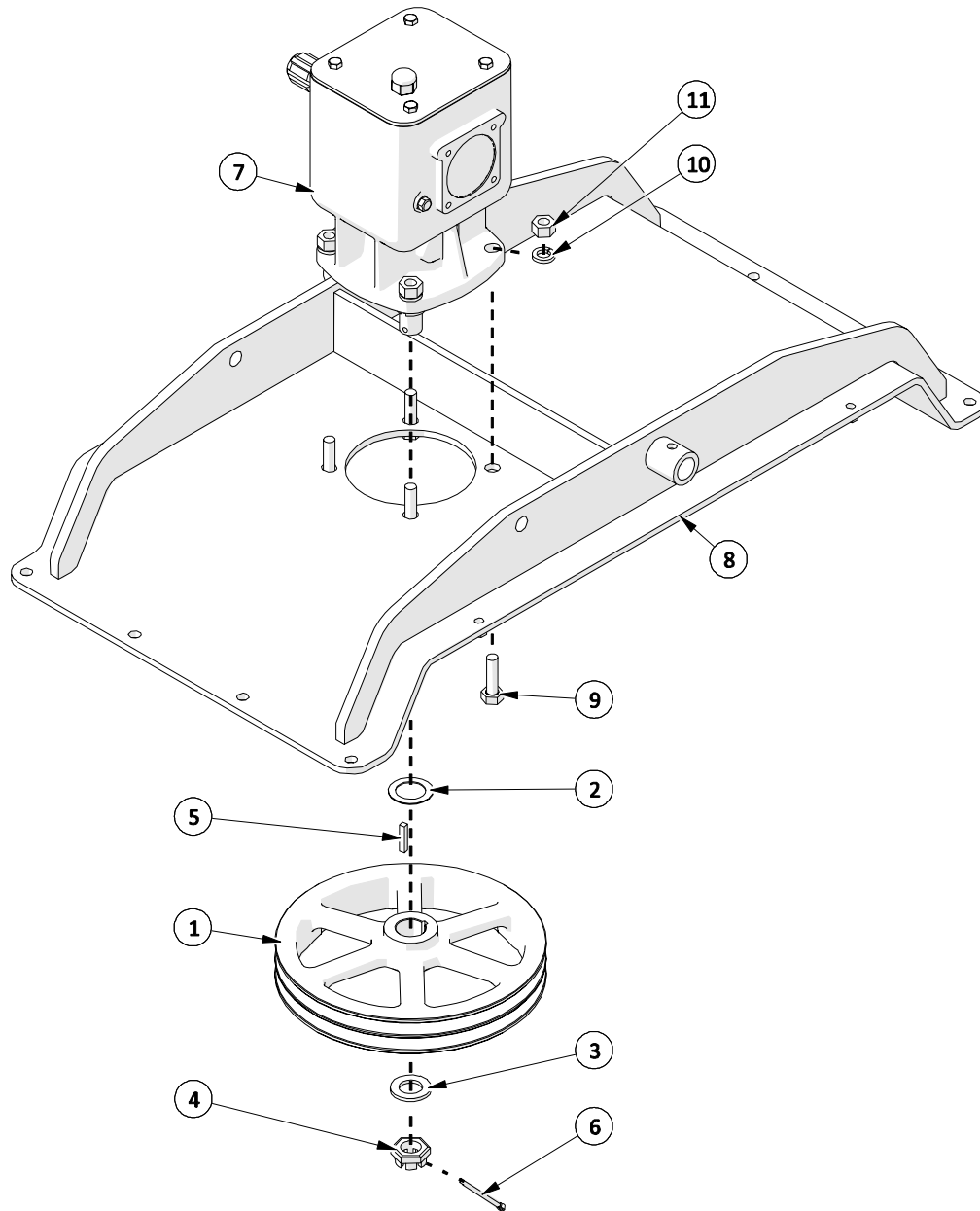

ITEM	PART #	DESCRIPTION	QTY
1	212021	PULLEY - 11-1/4"	1
2	521004	SHIM WASHER KIT (9 PCS)	1
3	521129	WASHER (3PCS)	1
4	521130	CASTLE NUT - M24	1
5	521390	DECK GEARBOX KEY (3 PCS)	1
6	O.L.	3/16 X 1-1/2" COTTER PIN	1
7	521432	DECK GEARBOX	1
8	526696	GEAR BOX MOUNT - WING	1
9	O.L.	HEX BOLT- 5/8 X 1.75 NC GR5 PL	4
10	O.L.	LOCK WASHER- 5/8 PL	4
11	O.L.	HEX NUT - 5/8NC GR5 PL	4

O.L. - OBTAIN LOCALLY

1.4 Rear Deck Gear Box Mount Assembly

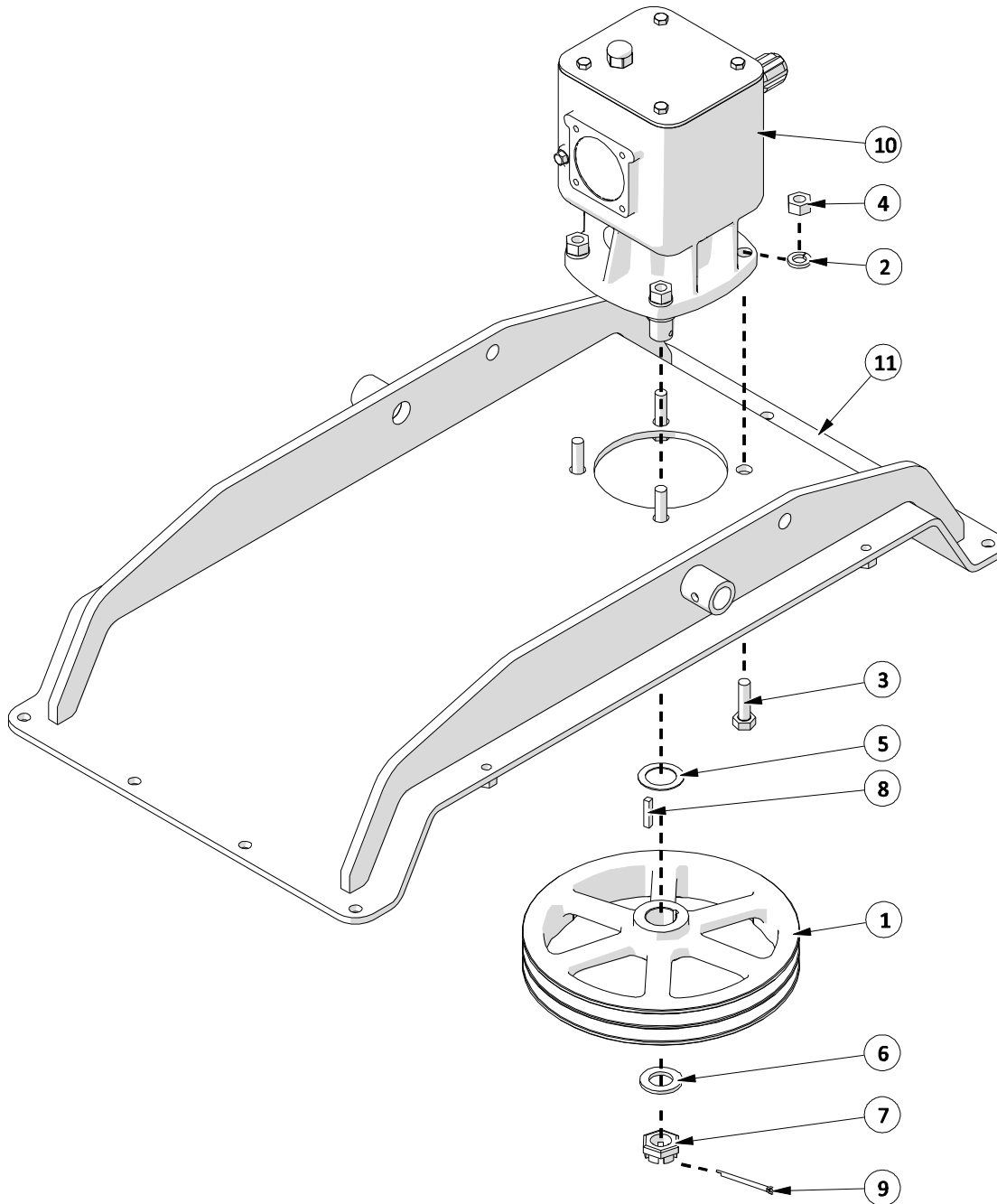

ITEM	PART #	DESCRIPTION	QTY
1	212021	PULLEY - 11-1/4"	1
2	O.L.	LOCK WASHER- 5/8 PL	4
3	O.L.	HEX BOLT- 5/8 X 1.75 NC GR5 PL	4
4	O.L.	HEX NUT - 5/8NC GR5 PL	4
5	521004	SHIM WASHER (9 PCS)	1
6	521129	WASHER KIT (3PCS)	1
7	521130	CASTLE NUT - M24	1
8	521390	DECK GEARBOX KEY (3 PCS)	1
9	O.L.	3/16 X 1-1/2" COTTER PIN	1
10	521432	DECK GEARBOX	1
11	526714	GEAR BOX MOUNT - REAR DECK	1

O.L. - OBTAIN LOCALLY

1.5 Wing Deck Assembly

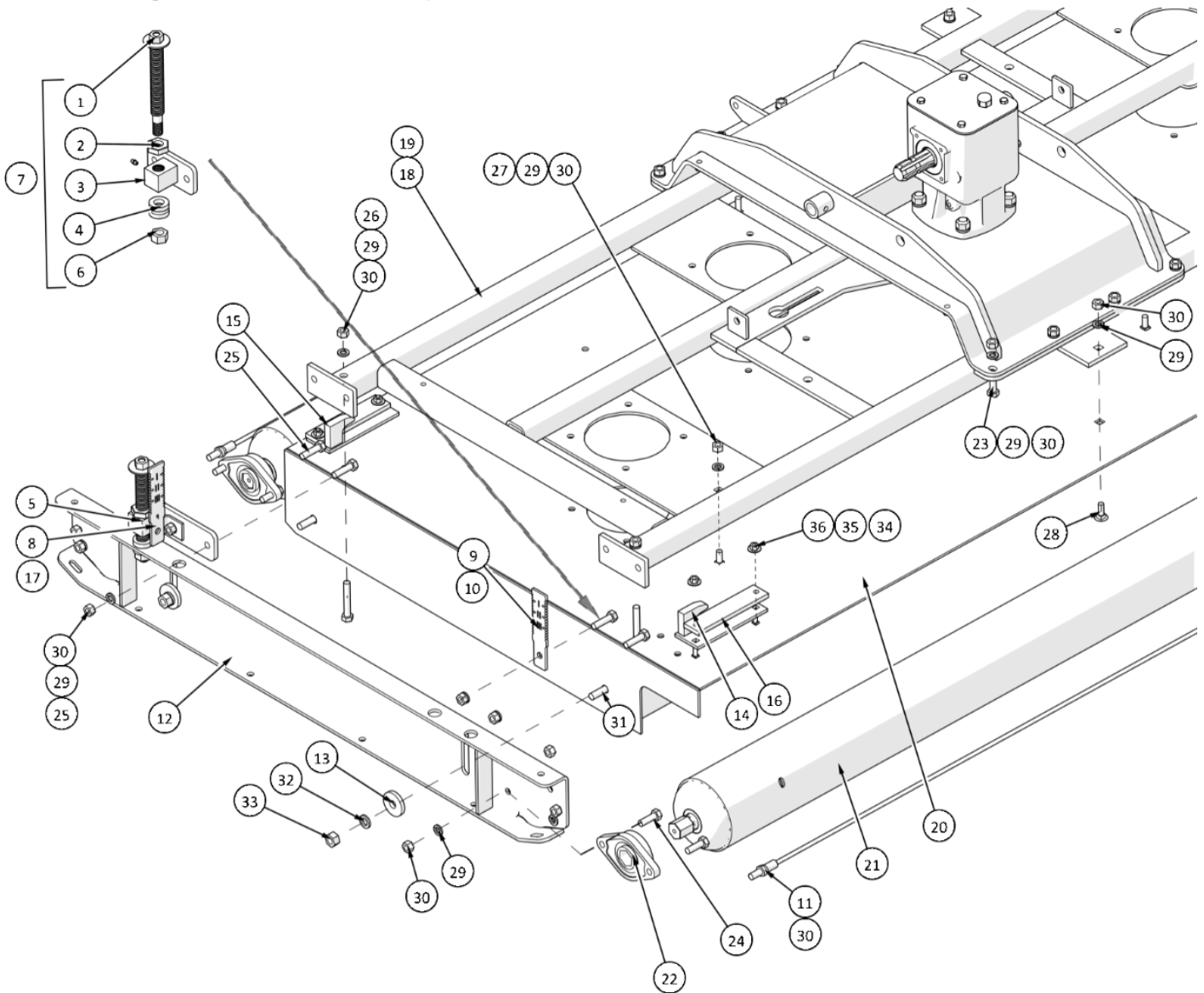

ITEM	PART #	DESCRIPTION	QTY
1	526176	HEIGHT ADJ. ROD	4
2	526144	JAM NUT - PL	4
3	SEE No. 7	DECK ADJUSTMENT BRACKET	3
4	607580	HEIGHT ADJ. BUSHING KIT (8 PCS)	1
5	526742	DECK ADJ. BRACKET - LONG	3
6	305715	CASTLE NUT - 3/4 NC	4
7	526252	HEIGHT ADJ. KIT (ONE CORNER)	1
8	SEE No. 10	HEIGHT INDICATOR PLATE - FRONT	2
9	SEE No. 10	HEIGHT INDICATOR PLATE- REAR	2
10	527606	HEIGHT PLATE KIT (4 PCS)	1
11	530022	WIPER CABLE - TDR 26	2
12	526186	DECK CHANNEL	2
13	526148	CLAMP WASHER KIT (4 PCS)	4
14	528386	DECK LOCK PLATE - LEFT	1
15	528382	DECK LOCK PLATE - RIGHT	1
16	607595	JHMW DECK STANDOFF PAD	2
17	527375	HEIGHT PLATE ANGLE	1
18	530008	TDR-26 RH DECK FRAME WELDMENT	1
19	530002	TDR-26 LH DECK FRAME WELDMENT	1

ITEM	PART #	DESCRIPTION	QTY
20	530024	DECK - TDR-26 - PAINTED	1
21	530005	ROLLER - TDR-26	2
22	213029	FLANGE BRG - 2 BOLT HEX	4
23	O.L.	HEX BOLT- 1/2 X 1.25 NC GR5 PL	8
24	O.L.	HEX BOLT- 1/2 X 1.5 NC GR5 PL	8
25	O.L.	HEX BOLT- 1/2 X 1.75 NC GR5 PL	8
26	O.L.	HEX BOLT- 1/2 X 3 NC GR5 PL	4
27	O.L.	CARR. BOLT- 1/2 X 1.25 NC GR5 PL	3
28	O.L.	CARR. BOLT- 1/2 X 1.75 NC GR5 PL	4
29	O.L.	LOCK WASHER- 1/2 PL	35
30	O.L.	HEX NUT - 1/2NC GR5 PL	41
31	O.L.	CARR. BOLT- 5/8 X 2 NC GR5 PL	4
32	O.L.	LOCK WASHER- 5/8 PL	4
33	O.L.	HEX NUT - 5/8NC GR5 PL	4
34	O.L.	CARR. BOLT- 3/8 X 1.25 NC GR5 PL	4
35	O.L.	FLAT WASHER- 3/8 PL	4
36	O.L.	HEX LOCK NUT - 3/8 NC GR5 PL	4

O.L. - OBTAIN LOCALLY

1.6 Wing Deck Shields

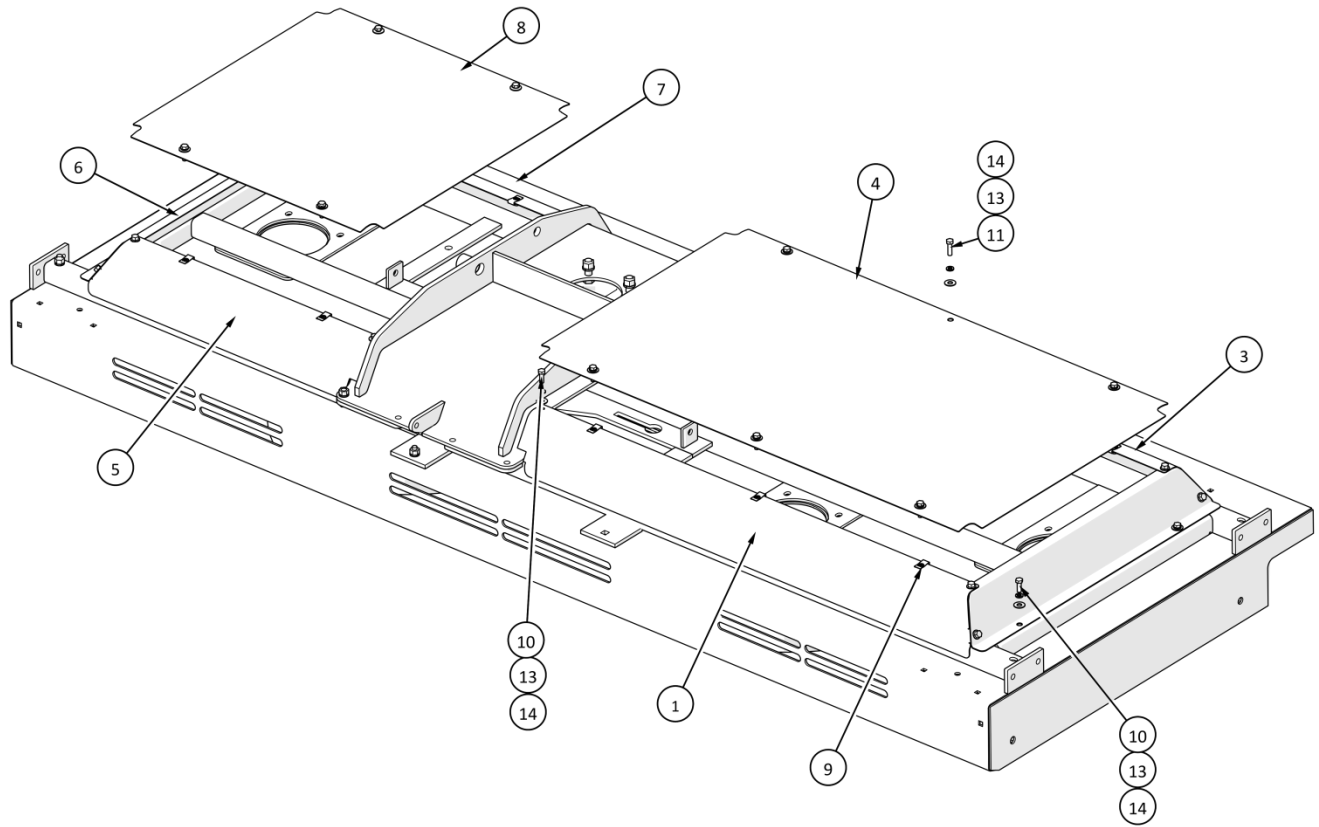

ITEM	PART #	DESCRIPTION	QTY
1	530017	DECK SHIELD SIDE - L.H.	1
2	527363	DECK SHIELD END	1
3	530015	DECK SHIELD SIDE - R.H.	1
4	530013	DECK SHIELD	1
5	527359	DECK SHIELD SIDE - R.H.	1
6	527363	DECK SHIELD END	1
7	527361	DECK SHIELD SIDE - L.H.	1
8	527367	DECK SHIELD	1

ITEM	PART #	DESCRIPTION	QTY
9	527308	3/8" U-NUT	10
10	O.L.	HEX BOLT- 3/8 X 1 NC GR5 PL	8
11	O.L.	HEX BOLT - 3/8 x 1.25 NC GR5 PL	10
12	O.L.	FLANGE BOLT - 3/8 X 5/8	8
13	O.L.	LOCK WASHER- 3/8 PL	26
14	O.L.	FLAT WASHER- 3/8 PL	18
15	O.L.	HEX NUT - 3/8NC GR5 PL	8

O.L. - OBTAIN LOCALLY

1.7 Wing Deck Drive

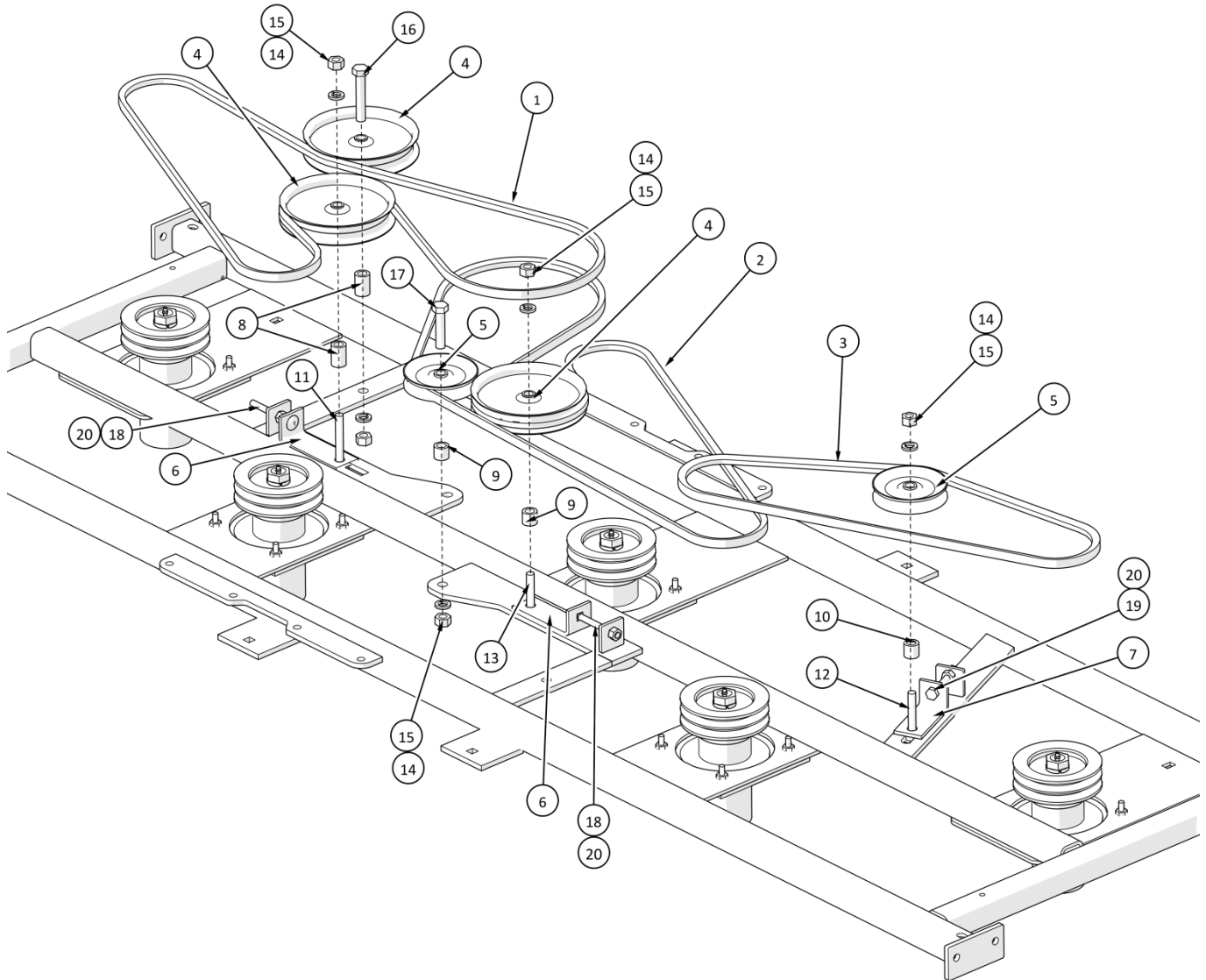

ITEM	PART #	DESCRIPTION	QTY
1	212046	BELT - B116	1
2	212045	BELT - B132	1
3	212035	BELT - B66	1
4	527097	IDLER PULLEY - 7" O.D.	3
5	212009	IDLER PULLEY - 5" O.D.	2
6	527103	IDLER PULLEY BRACKET	2
7	526331	IDLER PULLEY BRACKET	1
8	527229	PULLEY SPACER - 1.48	2
9	527225	PULLEY SPACER - 0.875	2
10	600225	PULLEY SPACER - 0.944	1
11	O.L.	CARR. BOLT- 5/8 X 4 NC GR5 PL	1

ITEM	PART #	DESCRIPTION	QTY
12	O.L.	CARR. BOLT- 5/8 X 3.5 NC GR5 PL	1
13	O.L.	CARR. BOLT- 5/8 X 3 NC GR5 PL	1
14	O.L.	LOCK WASHER- 5/8 PL	5
15	O.L.	HEX NUT - 5/8NC GR5 PL	5
16	O.L.	HEX BOLT- 5/8 X 3.5 NC GR5 PL	1
17	O.L.	HEX BOLT- 5/8 X 2.75 NC GR5 PL	1
18	O.L.	CARR. BOLT- 1/2 X 4 NC GR5 PL	2
19	O.L.	HEX TAP BOLT- 1/2 X 3.5 NC GR5 PL	1
20	O.L.	HEX NUT - 1/2NC GR5 PL	6

O.L. - OBTAIN LOCALLY

1.8 Rear Deck Assembly

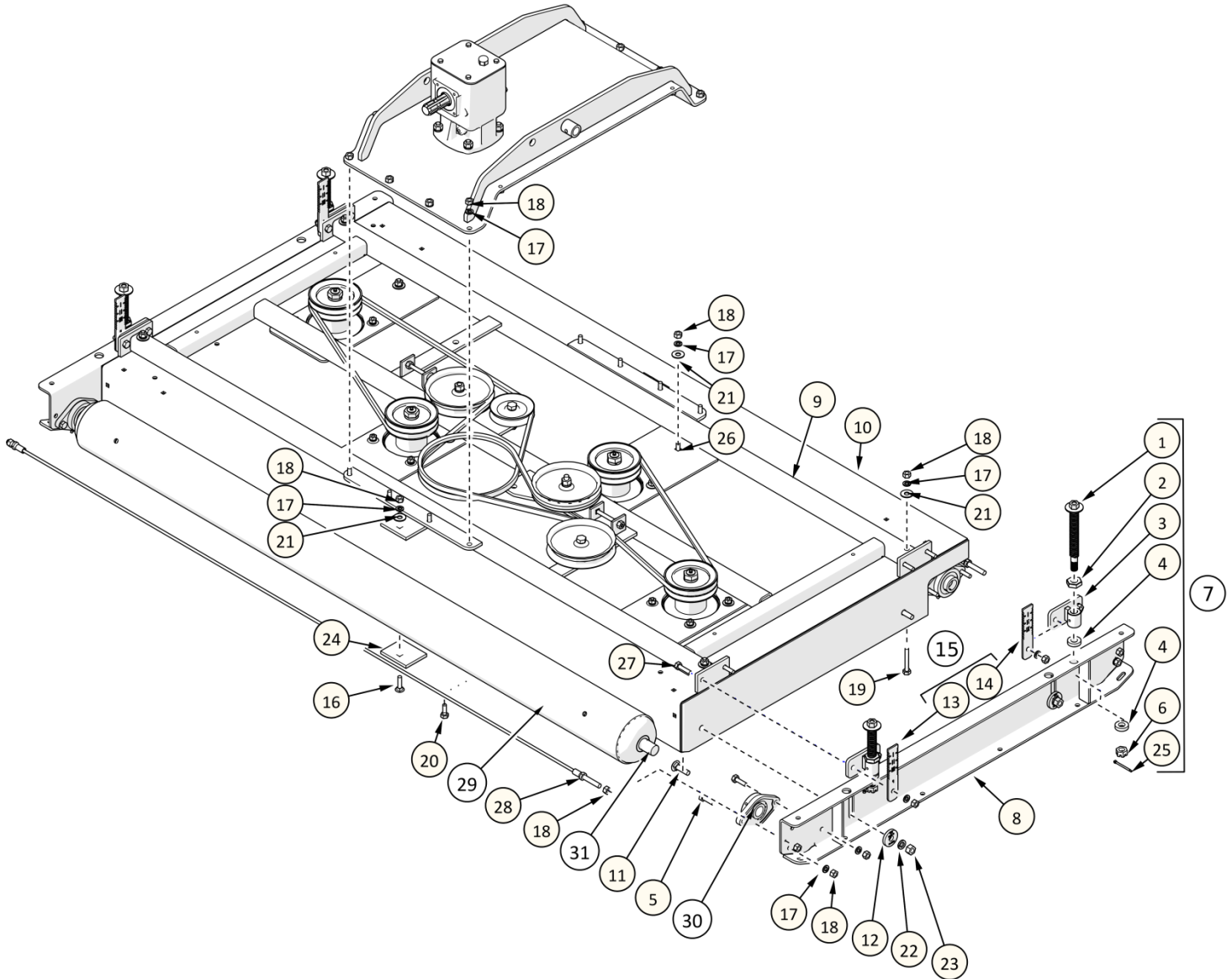

ITEM	PART #	DESCRIPTION	QTY
1	SEE ITEM 7	HEIGHT ADJ. ROD	4
2	526144	ACME JAM NUT	4
3	SEE ITEM 7	DECK ADJUSTMENT BRACKET	4
4	607580	HEIGHT ADJ. BUSHING KIT (8 PCS)	8
5	O.L.	HEX BOLT - 1/2" X 1.50 NC GR5 PL	8
6	SEE ITEM 7	CASTLE NUT - 3/4" NC GR5 PL	1
7	526252	TDR HEIGHT ADJ. KIT	1
8	526946	DECK CHANNEL - GALV	2
9	526646	DECK FRAME	1
10	526382	DECK - GALVANIZED	1
11	O.L.	CARR. BOLT - 5/8" X 2.00 NC GR5 PL	4
12	526148	CLAMP WASHER KIT (4 PCS)	4
13	SEE ITEM 15	HEIGHT INDICATOR PLATE - FRONT	2
14	SEE ITEM 15	HEIGHT INDICATOR PLATE - REAR	2
15	527606	TDR HEIGHT PLATE KIT (4 PCS)	1
16	O.L.	CARR. BOLT - 1/2" X 1.75" NC GR5 PL	2

ITEM	PART #	DESCRIPTION	QTY
17	O.L.	LOCKWASHER - 1/2" PL	32
18	O.L.	HEX NUT - 1/2" NC GR5 PL	36
19	O.L.	HEX BOLT - 1/2" X 3.00 NC GR5 PL	4
20	O.L.	HEX BOLT - 1/2" X 1.25 NC GR5 UPL	8
21	O.L.	FLAT WASHER - 1/2" PL	8
22	O.L.	LOCKWASHER - 5/8" PL	4
23	O.L.	HEX NUT - 5/8" NC GR5 PL	4
24	526175	BOTTOM PLATE	1
25	O.L.	COTTER PIN - 3/16" X 1.50	4
26	O.L.	CARR. BOLT - 1/2" X 1.25" NC GR5 PL	2
27	O.L.	HEX BOLT - 1/2" X 1.75 NC GR5 PL	8
28	607649	WIPER CABLE - REAR	2
29	607706	ROLLER - TDR 22 HEX /W SHAFTS	2
30	213029	FLANGE BRG - 2 BOLT HEX	4
31	607705	HEX SHAFT REPLACEMENT KIT	1

O.L. - OBTAIN LOCALLY

1.9 Rear Deck Shields

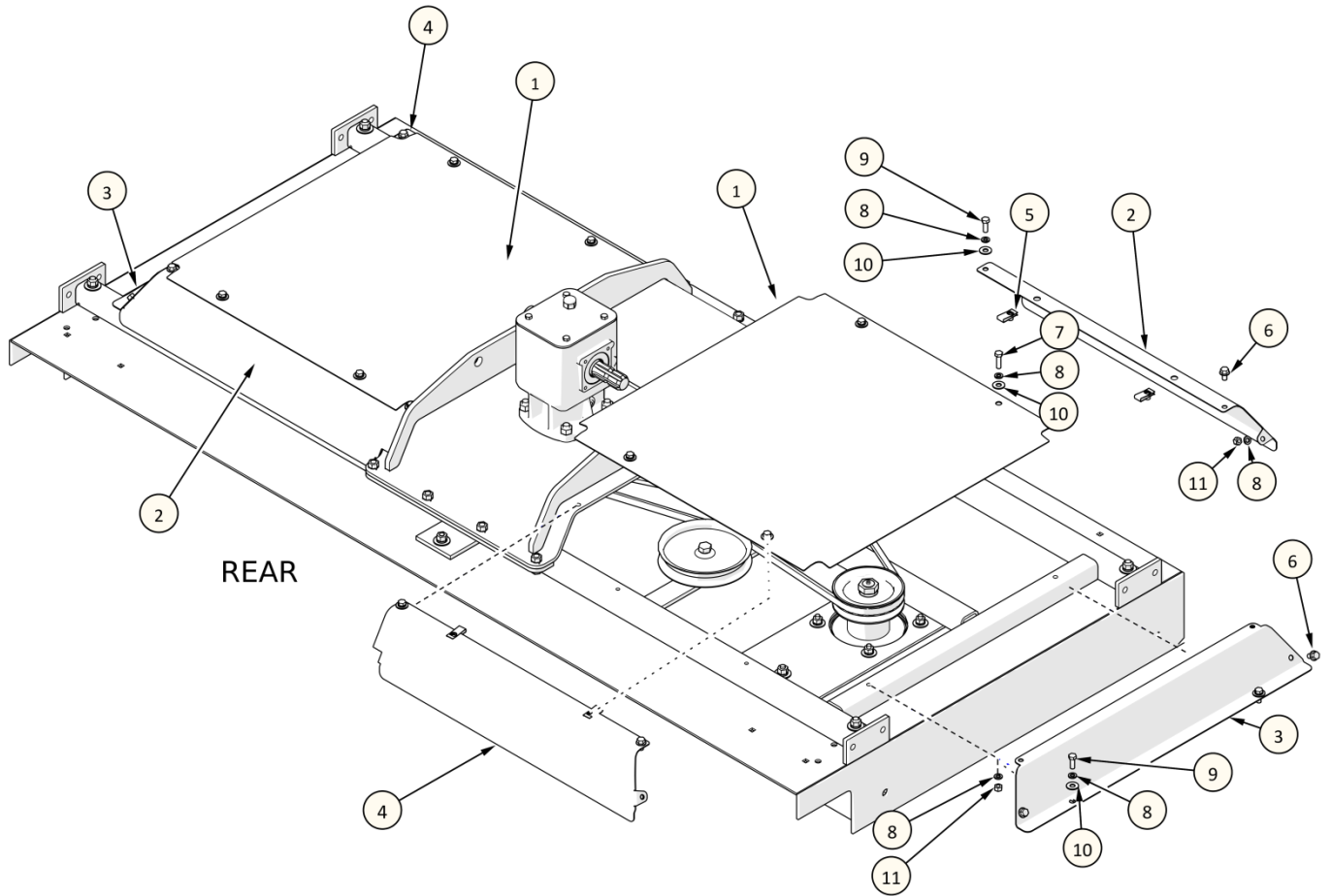

ITEM	PART #	DESCRIPTION	QTY
1	527367	DECK SHIELD	2
2	527359	DECK SHIELD SIDE - R.H.	2
3	527363	DECK SHIELD END	2
4	527361	DECK SHIELD SIDE - L.H.	2
5	527308	U-NUT - 3/8" NC	8
6	O.L.	FLANGE BOLT - 3/8 X 5/8	4
7	O.L.	HEX BOLT - 3/8 x 1.25 NC GR5 PL	4
8	O.L.	LOCK WASHER- 3/8 PL	12
9	O.L.	HEX BOLT- 3/8 X 1 NC GR5 PL	4
10	O.L.	FLAT WASHER- 3/8 PL	8
11	O.L.	HEX NUT - 3/8NC GR5 PL	4

O.L. - OBTAIN LOCALLY

1.10 Rear Deck Drive

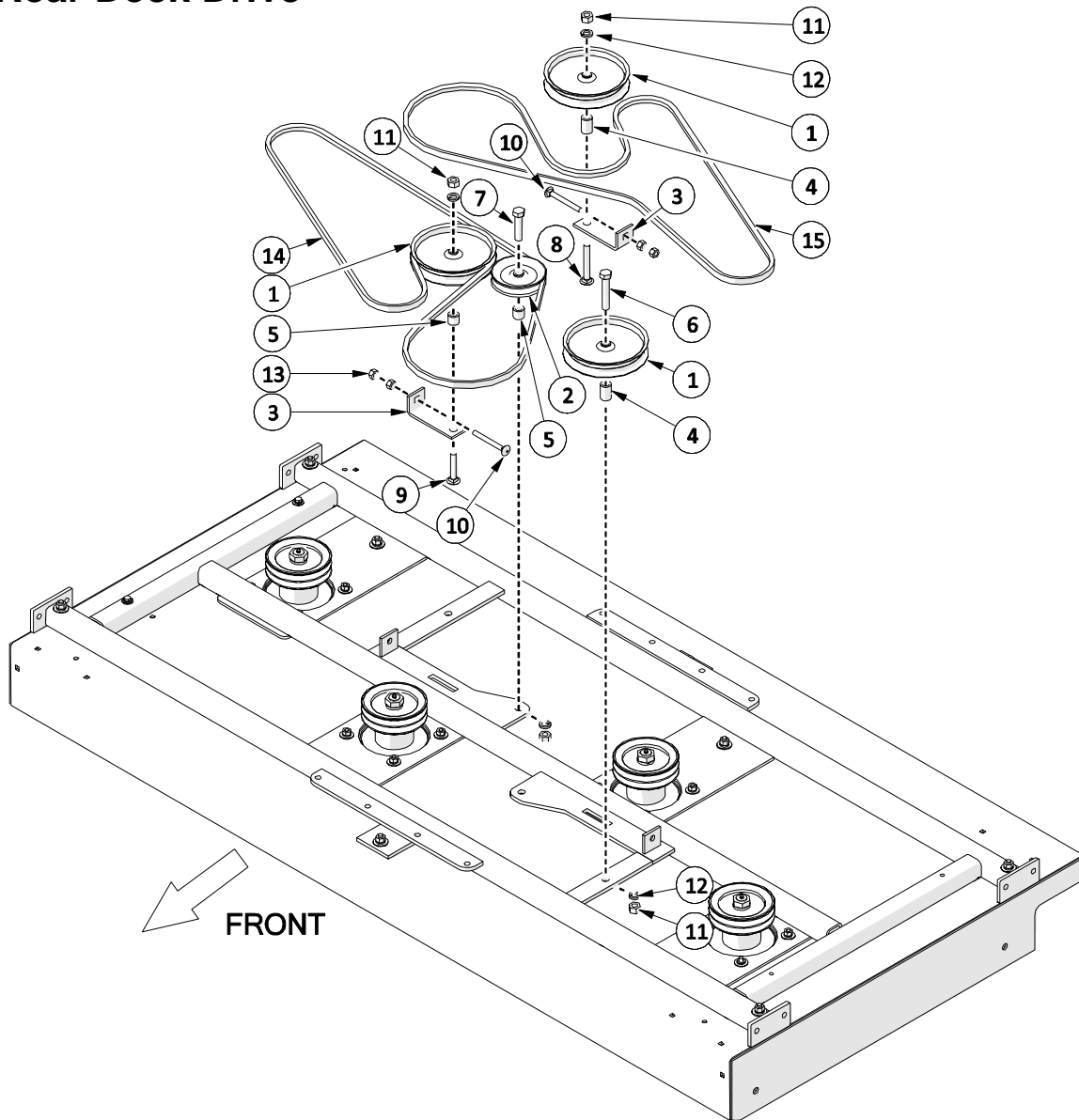

ITEM	PART #	DESCRIPTION	QTY
1	527097	IDLER PULLEY-7"	3
2	212009	IDLER PULLEY-5"	1
3	527103	IDLER PULLEY BRACKET	2
4	527229	PULLEY SPACER - 1.48"	2
5	527225	PULLEY SPACER - 0.875"	2
6	O.L.	HEX BOLT- 5/8" X 3.50 NC GR5 PL	1
7	O.L.	HEX BOLT- 5/8" X 2.75 NC GR5 PL	1
8	O.L.	CARRIAGE BOLT - 5/8" X 4.00 NC GR5 PL	1
9	O.L.	CARRIAGE BOLT - 5/8" X 3.00 NC GR5 PL	1
10	O.L.	CARRIAGE BOLT - 1/2" X 4.00 NC GR5 PL	2
11	O.L.	HEX NUT - 5/8"NC GR5 PL	4
12	O.L.	LOCKWASHER - 5/8"	4
13	O.L.	HEX NUT - 1/2"NC GR5 PL	4
14	212045	BELT - B132	1
15	212046	BELT - B117	1

O.L. - OBTAIN LOCALLY

2 Frame Assembly

2.1 Frame Assembly

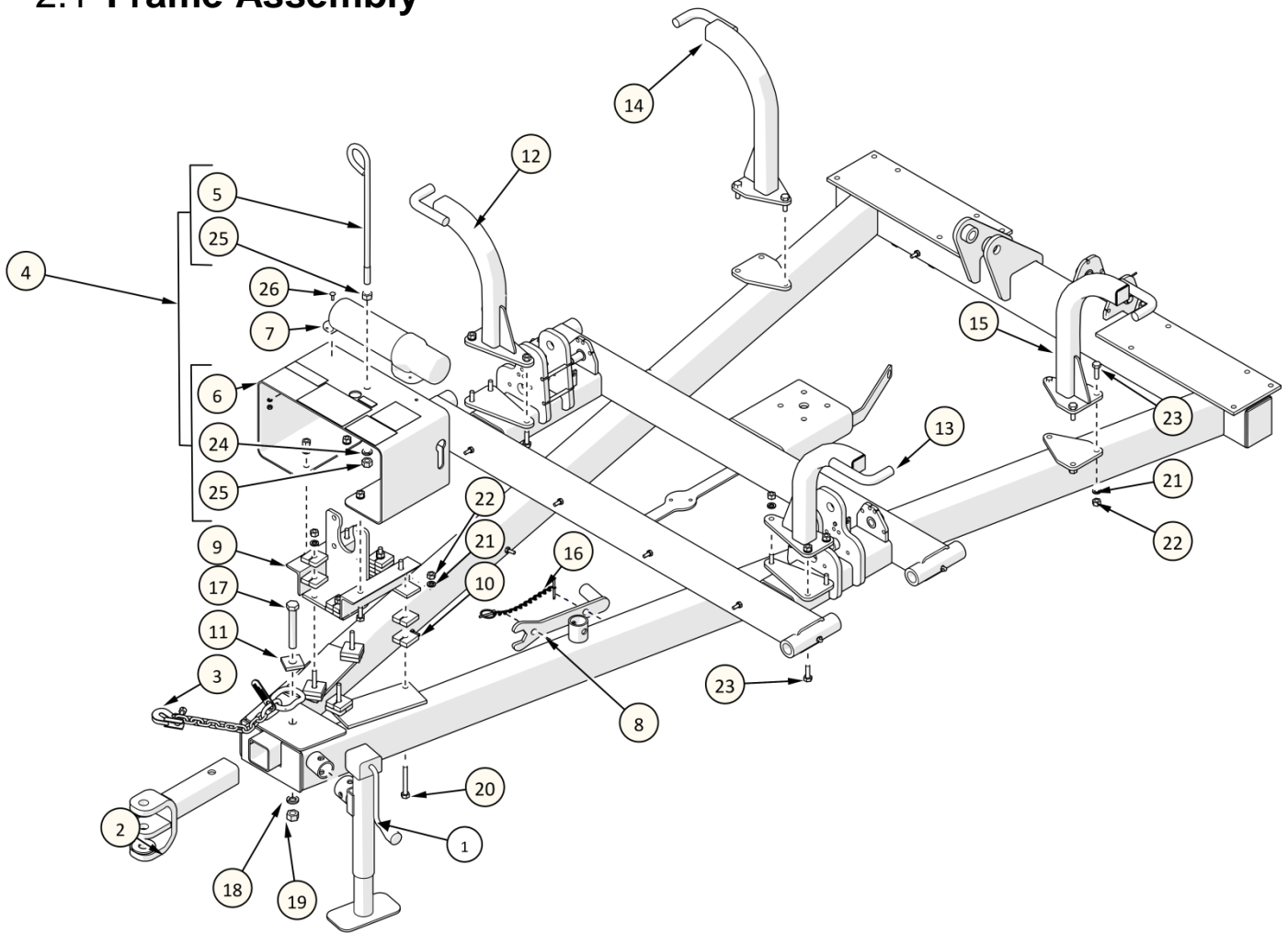

ITEM	PART #	DESCRIPTION	QTY
1	219006	IMPLEMENT JACK	1
2	521047	4 POSITION HITCH	1
3	521048	SAFETY CHAIN	1
4	522408	HOSE SUPPORT - COMPLETE	1
5	522413	HOSE GUIDE - W/ HARDWARE	1
6	ITEM No. 4	HOSE SUPPORT	1
7	120519	MANUAL HOLDER TUBE	1
8	526094	TDR HEIGHT ADJUST WRENCH	1
9	522402	PTO MOUNTING BRKT	1
10	522414	PTO BRACKET SPACER KIT (4 PC)	1
11	521857	SAFETY CHAIN FLAT WASHER	1
12	526668	DECK STANDOFF - FRONT RIGHT	1
13	526674	DECK STANDOFF - FRONT LEFT	1
14	526670	DECK STANDOFF - REAR RIGHT	1

ITEM	PART #	DESCRIPTION	QTY
15	526672	DECK STANDOFF - REAR LEFT	1
16	302910	LYNCH PIN - 3/16" RD W/ CHAIN	1
17	O.L.	HEX BOLT - 3/4" X 5.00 NC GR5 PL	1
18	O.L.	LOCKWASHER - 3/4" PL	1
19	O.L.	HEX NUT - 3/4"NC GR5 PL	1
20	O.L.	TAP BOLT - 1/2" X 3.50 NC GR5 PL	5
21	O.L.	LOCKWASHER - 1/2"	18
22	O.L.	HEX NUT - 1/2"NC GR5 PL	18
23	O.L.	HEX BOLT - 1/2" X 1.50 NC GR 5PL	12
24	O.L.	LOCKWASHER - 5/8" PL	1
25	O.L.	HEX NUT - 5/8"NC GR5 PL	2
26	O.L.	CARR. BOLT - 1/4" X .75 NC GR5 PL	2

O.L. - OBTAIN LOCALLY

2.2 Wing Locks

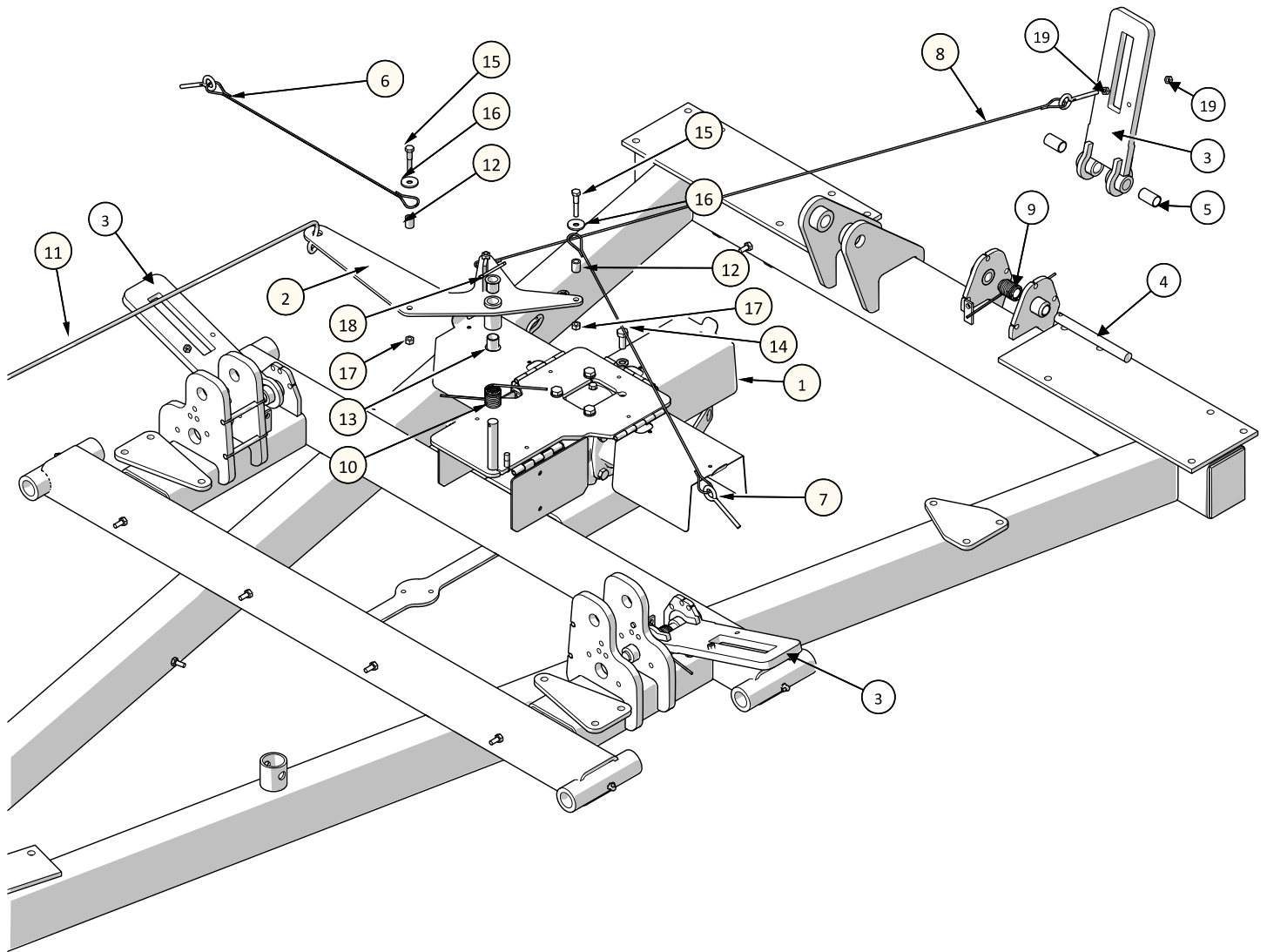

ITEM	PART #	DESCRIPTION	QTY
1	526618	4-WAY GEARBOX SHIELD	1
2	526684	LOCK RELEASE SWIVEL	1
3	526676	WING LOCK	3
4	527231	LOCK PIN	3
5	213080	BUSHING KIT - 6PC	1
6	526956	LOCK RELEASE CABLE - LEFT	1
7	526954	LOCK RELEASE CABLE - RIGHT	1
8	526952	LOCK RELEASE CABLE - REAR	1
9	527245	WING LOCK SPRING - RH WIND	3
10	527247	WING LOCK SPRING - LH WIND	1

ITEM	PART #	DESCRIPTION	QTY
11	526474	PULL ROPE	1
12	214009	BUSHING KIT - 2PC	3
13	527350	FLANGE BUSHING KIT (2 PCS)	2
14	521764	M12 BOLT & L.W KIT (16 PCS)	4
15	O.L.	HEX BOLT - 3/8" X 1.75 NC GR5 PL	3
16	O.L.	FENDER WASHER - 3/8" PL	3
17	O.L.	HEX NUT - 3/8" NC GR5 PL	3
18	O.L.	COTTER PIN - 3/16" X 2.00	1
19	O.L.	HEX NUT - 5/16"NC GR5 PL	6

O.L. - OBTAIN LOCALLY

2.3 Wing Assembly

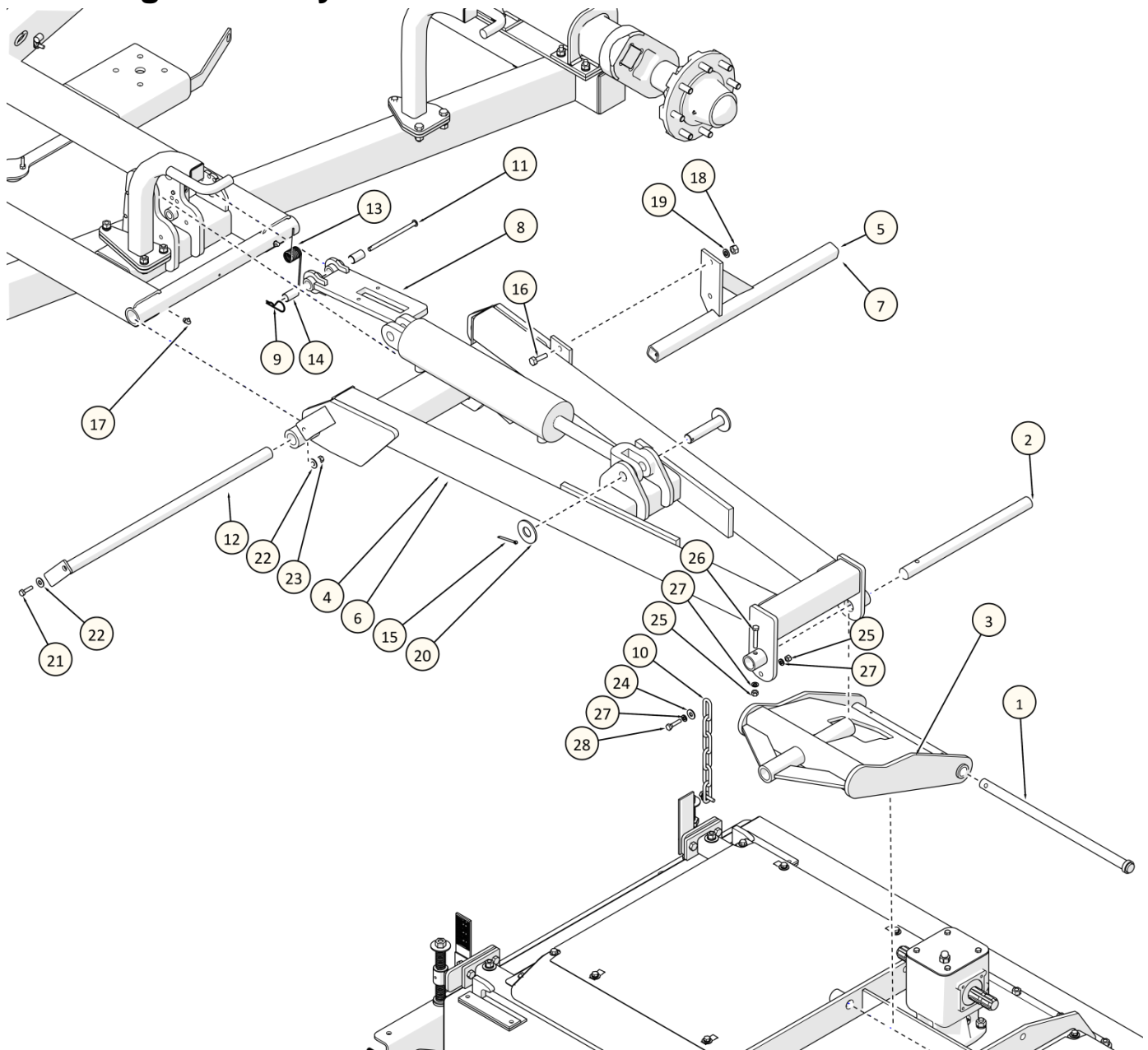

ITEM	PART #	DESCRIPTION	QTY
1	526720	DECK LIFT PIN	1
2	527255	SWIVEL PIN	1
3	607384	DECK SWIVEL	1
4	607188	WING FRAME - LH (SHOWN)	1
5	526690	DECK STABILIZER L.H. (SHOWN)	1
6	607260	WING FRAME - R.H. (NOT SHOWN)	1
7	526688	DECK STABILIZER R.H. (NOT SHOWN)	1
8	526676	WING LOCK	1
9	O.L.	HAIR PIN - .093" X 1-5/8"	1
10	526972	DECK STOP CHAIN	1
11	607304	LOCK STOP PIN	1
12	526178	WING PIN	1
13	527245	WING LOCK SPRING R.H. WIND	1
14	213080	SLEEVE BEARING KIT - 6 PCS	1
15	O.L.	COTTER PIN - 3/16" X 1.50	1

ITEM	PART #	DESCRIPTION	QTY
16	O.L.	HEX BOLT - 1/2" X 1.50 NC GR5 PL	2
17	O.L.	GREASE FITTING - 90 DEG	2
18	O.L.	HEX NUT - 1/2"NC GR5 PL	8
19	O.L.	LOCK WASHER- 1/2" PL	8
20	O.L.	FLAT WASHER- 1" PL	1
21	O.L.	HEX BOLT - 3/8" X 1.25 NC GR5 PL	1
22	O.L.	FLAT WASHER- 3/8" PL	2
23	O.L.	HEX LOCK NUT - 3/8"NC GR5 PL	1
24	O.L.	HARDENED FLAT WASHER - 3/8"	2
25	O.L.	HEX NUT - 3/8"NC GR5 PL	3
26	O.L.	HEX BOLT - 3/8" X 2.00" NC GR5 PL	2
27	O.L.	LOCK WASHER- 3/8" PL	5
28	O.L.	HEX BOLT- 3/8" X 1.50 NC GR5 PL	2

O.L. - OBTAIN LOCALLY

2.4 Rear Lift Assembly

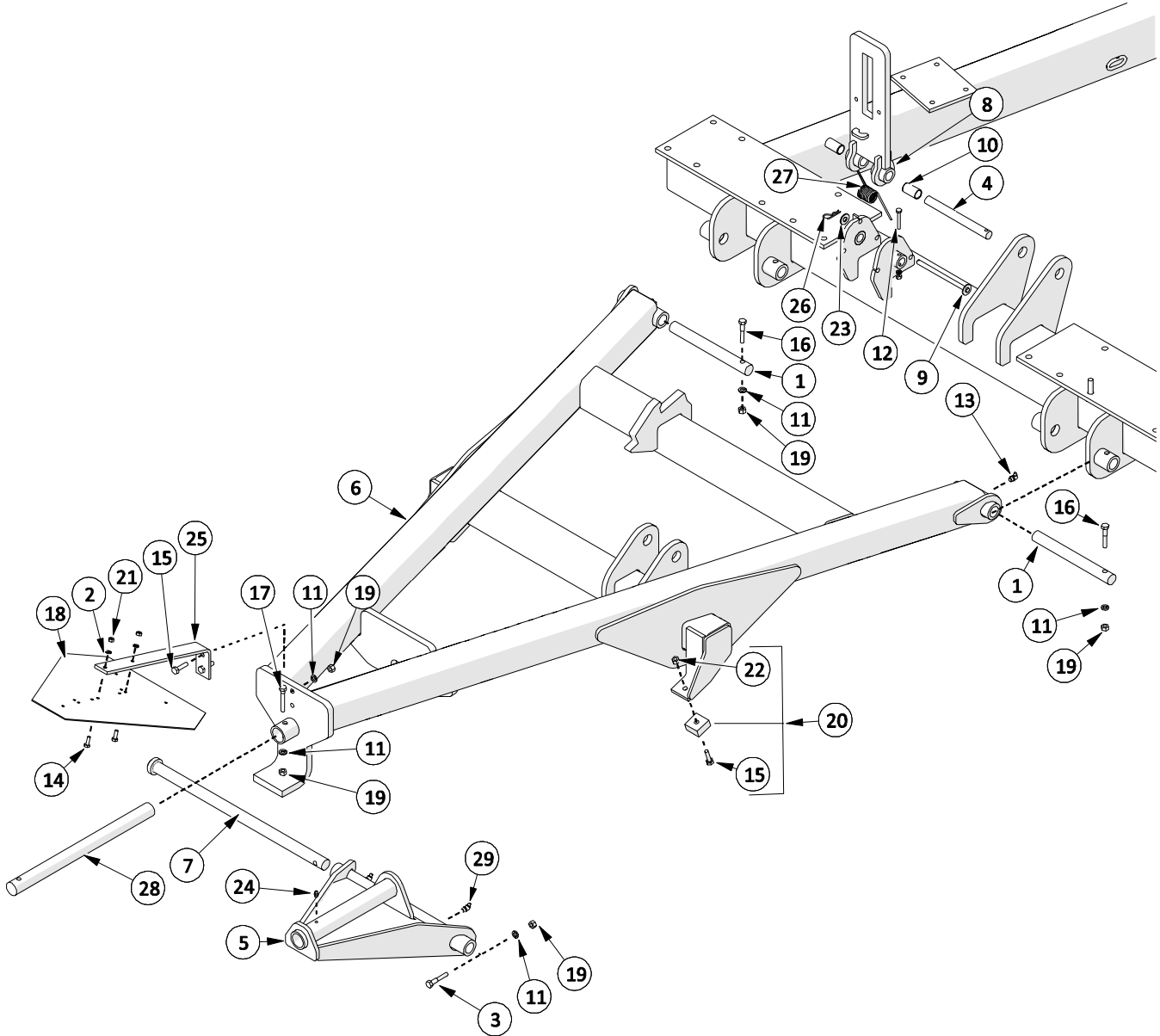

ITEM	PART #	DESCRIPTION	QTY
1	527243	REAR LIFT PIN	2
2	O.L.	LOCK WASHER- 1/4 PL	2
3	O.L.	HEX BOLT- 3/8 X 2 NC GR8 PL	1
4	527231	LOCK PIN	1
5	526704	REAR DECK SWIVEL	1
6	526716	REAR DECK LIFT	1
7	526720	DECK LIFT PIN	1
8	526676	WING LOCK	1
9	526962	LOCK STOP PIN	1
10	213080	SLEEVE BEARING KIT (6 PCS)	1
11	O.L.	LOCK WASHER- 3/8 PL	6
12	O.L.	1/4" x 1.25" HEX BOLT W/ L.W. & HEX NUT	1
13	O.L.	GREASE FITTING - 1/4-28, 90 DEG	6
14	O.L.	CARRIAGE BOLT - 1/4 x .75 NC GR5 PL	2
15	O.L.	HEX BOLT - 38 x 1.50 NC GR5 PL	4

ITEM	PART #	DESCRIPTION	QTY
16	O.L.	HEX BOLT- 3/8 X 2 NC GR5 PL	2
17	O.L.	HEX BOLT- 3/8 X 2.25 NC GR5 PL	1
18	521353	SMV SIGN	1
19	O.L.	HEX NUT - 3/8NC GR5 PL	6
20	600512	BUMPER KIT (4 PCS W/HARDWARE)	1
21	O.L.	HEX NUT - 1/4NC GR5 PL	2
22	O.L.	HEX LOCK NUT - 3/8 NC GR5 PL	2
23	O.L.	FLAT WASHER- 3/8 UPL	1
24	O.L.	GREASE FITTING - 1/4-28, STRAIGHT	1
25	527223	SMV BRACKET	1
26	O.L.	HAIR PIN - .093" X 1-5/8"	1
27	527245	WING LOCK SPRING R.H. WIND	1
28	527255	SWIVEL PIN	1
29	O.L.	GREASE FITTING - 1/4-28, 45 DEG	2

O.L. - OBTAIN LOCALLY

2.5 Wheel Assemblies

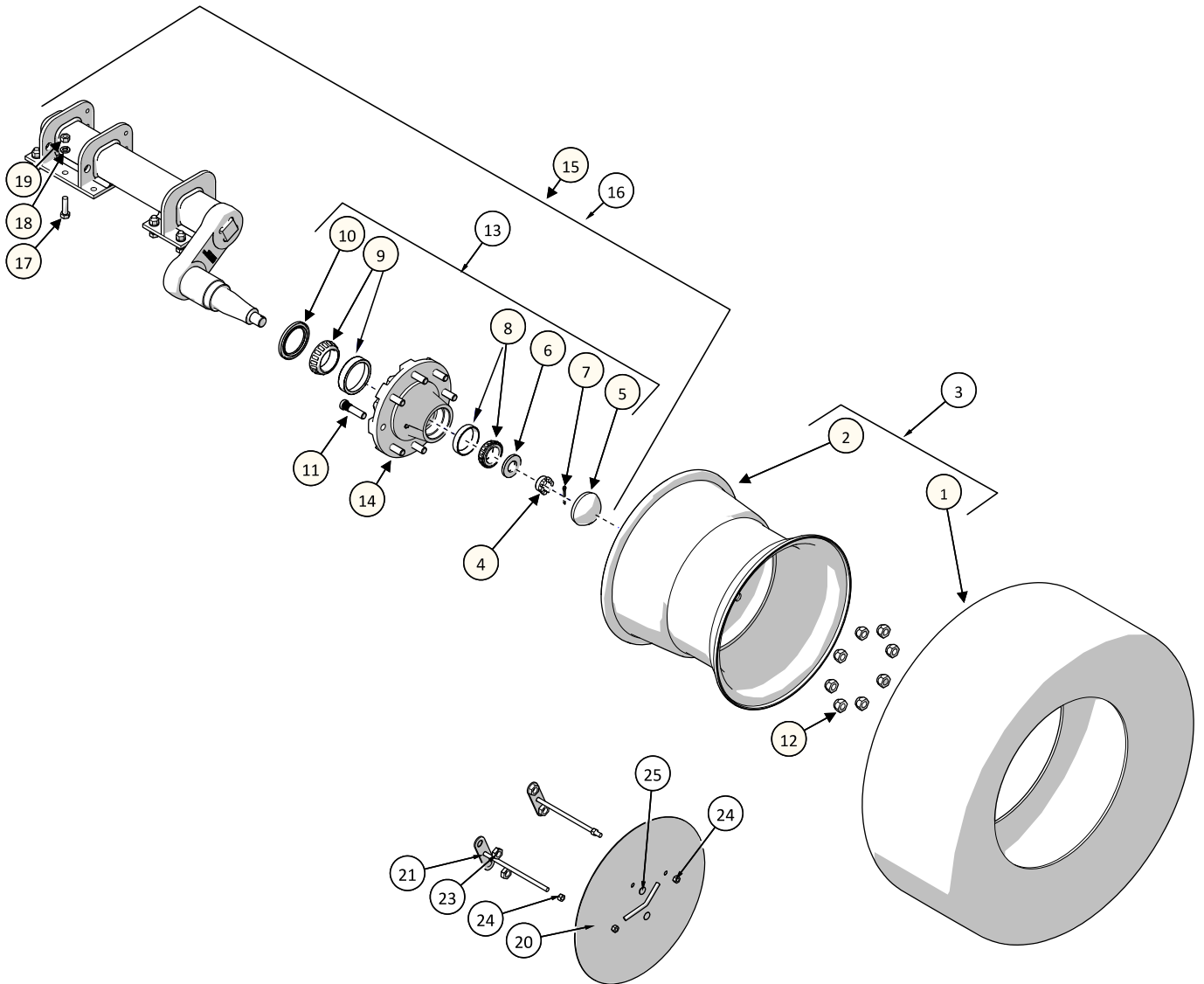

ITEM	PART #	DESCRIPTION	QTY
1	230059	TRANSPORT TIRE	1
2	230058	RIM	1
3	230057	TIRE & RIM ASSEMBLY	1
4	526914	CASTLE NUT	1
5	526918	DUST CAP	1
6	-	BEARING WASHER	1
7	O.L.	COTTER PIN - 5/32" X 1.50	1
8	-	OUTER BEARING	1
9	-	INNER BEARING	1
10	-	GREASE SEAL	1
11	526916	WHEEL STUD KIT (8 PCS)	1
12	526964	WHEEL NUT KIT (8 PCS)	1
13	526996	HUB REBUILD KIT (ITEMS 5-10)	1

ITEM	PART #	DESCRIPTION	QTY
14	526998	HUB ASSEMBLY - W/BEARINGS	1
15	527494	RH AXLE ASSEMBLY (SHOWN)	1
16	527492	LH AXLE ASSEMBLY (NOT SHOWN)	1
17	O.L.	HEX BOLT- 1/2" X 1.75 NF GR8 PL	6
18	O.L.	LOCK WASHER- 1/2" PL	6
19	O.L.	HEX NUT - 1/2"NC GR5 PL	6
20	607320	WHEEL DISC - W.A.	1
21	607326	MTG PLATE - WHEEL DISC	2
23	O.L.	JAM NUT - 5/8 UNF - GR5	4
24	O.L.	HEX LOCK NUT - 3/8 NC GR5 PL	4
25	607736	3/8" SNAP IN PLUG (5 PCS)	1

O.L. - OBTAIN LOCALLY

3 HYDRAULICS

3.1 Hydraulics

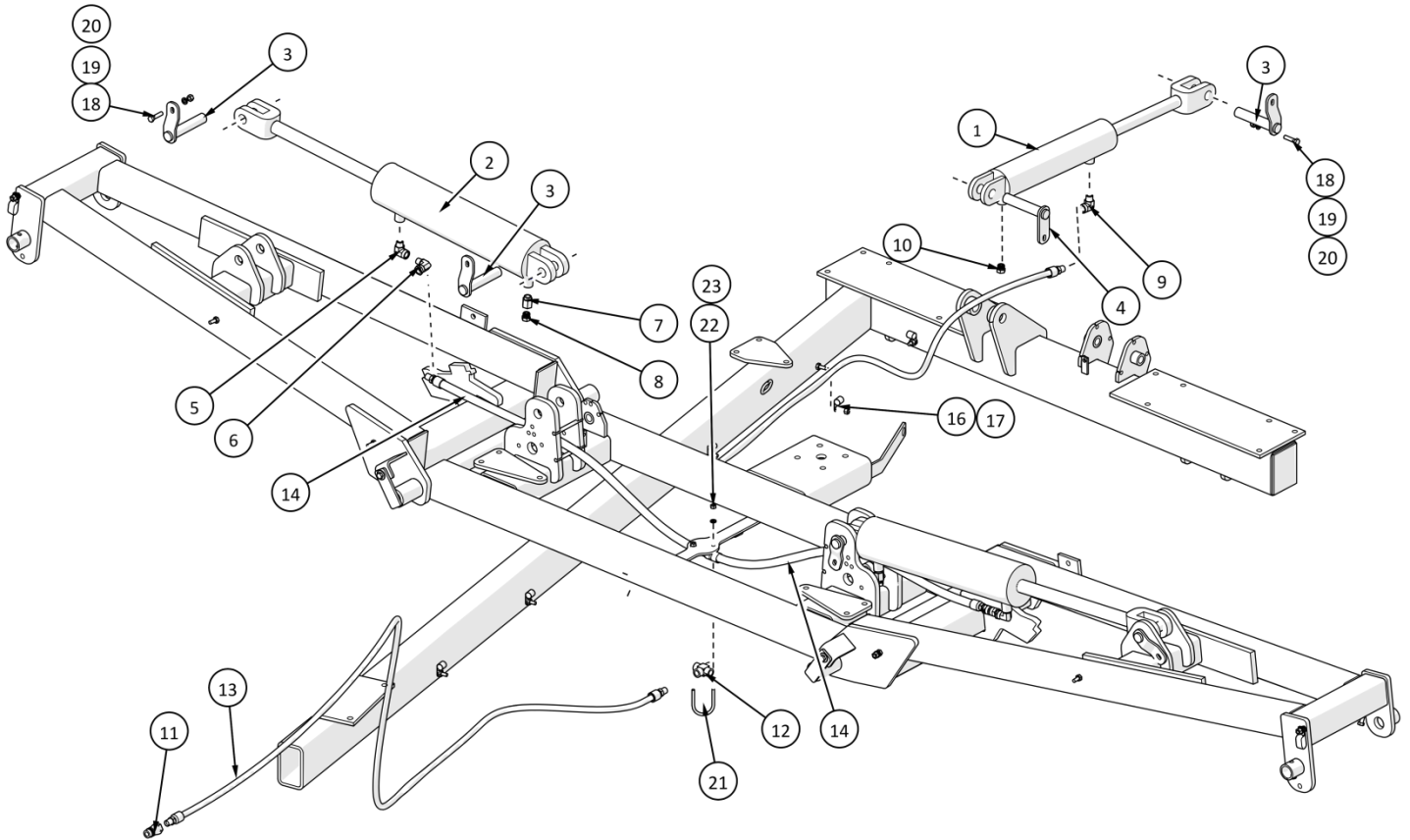

ITEM	PART #	DESCRIPTION	QTY
1	522016	HYDRAULIC CYL. - REAR	1
2	530030	HYDRAULIC CYL. - WING	2
3	607398	PIN - CYLINDER	5
4	607402	REAR CYL BASE PIN	1
5	222013	ELBOW - -8 ORB X 3/8" NPT	2
6	521336	ELBOW - RESTRICTOR	2
7	221054	ADAPTER ORB-NPTF	2
8	221141	BREATHER VENT - 1/2" NPT	2
9	521364	RESTRICTOR - REAR CYL.	1
10	221140	BREATHER VENT - 3/8" NPT	1
11	222006	HOSE END KIT (2 PCS)	1
12	521070	HYDRAULIC CROSS	1

ITEM	PART #	DESCRIPTION	QTY
13	521334	HYDRAULIC HOSE - 122"	1
14	526974	HYDRAULIC HOSE - 45"	2
15	526970	HYDRAULIC HOSE - 94"	1
16	229011	5/8" SINGLE TUBE CLAMP	5
17	O.L.	HEX LOCK NUT - 3/8" NC GR5 UPL	5
18	O.L.	HEX BOLT- 3/8 X 1.5 NC GR5 PL	2
19	O.L.	LOCKWASHER - 3/8" PL	5
20	O.L.	HEX NUT - 3/8"NC GR5 PL	5
21	304202	U BOLT - 5/16" NC	1
22	O.L.	HEX NUT - 5/16"NC GR5 PL	2
23	O.L.	LOCKWASHER - 5/16" PL	2

O.L. - OBTAIN LOCALLY

4 DRIVELINE

4.1 Driveline

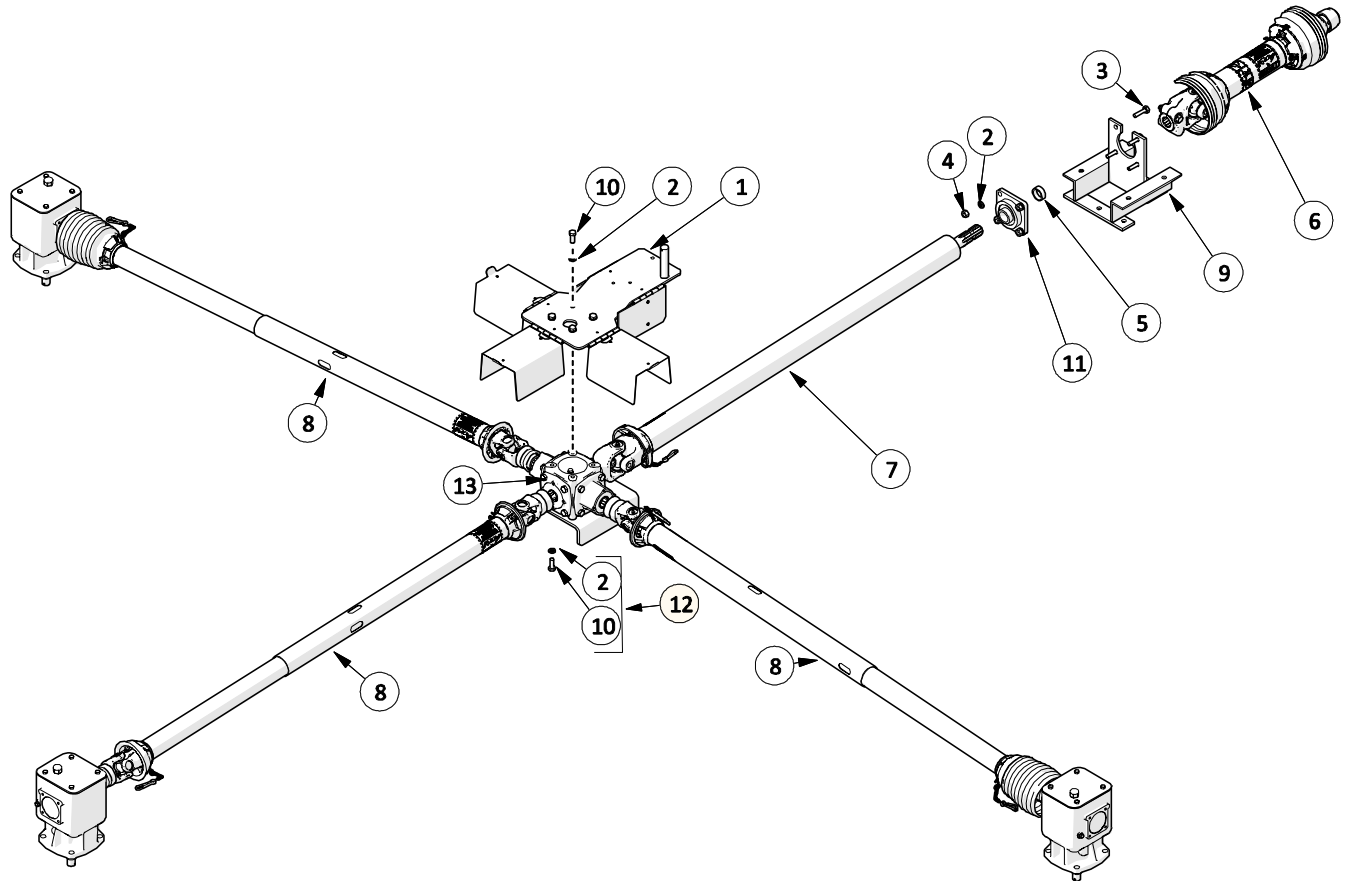

ITEM	PART #	DESCRIPTION	QTY
1	526618	4 WAY GEARBOX SHIELD	1
2	O.L.	LOCK WASHER- 1/2 PL	12
3	O.L.	HEX BOLT- 1/2 X 1.75 NC GR5 PL	4
4	O.L.	HEX NUT - 1/2NC GR5 PL	4
5	521789	PTO SPACER	1
6	210150	INPUT PTO SHAFT	1
7	210170	INTERMEDIATE PTO SHAFT	1
8	210190	DECK PTO SHAFT	3
9	522402	PTO MOUNTING BRACKET	1
10	SEE ITEM 12	HEX BOLT - M12 X 30GR 8.8	8
11	521323	4 BOLT FLANGE BEARING	1
12	521764	M12 BOLT & LOCKWASHER KIT (16 PCS)	1
13	521497	GEAR BOX - 4 SHAFT	1

O.L. - OBTAIN LOCALLY

4.2 Deck PTO Shaft

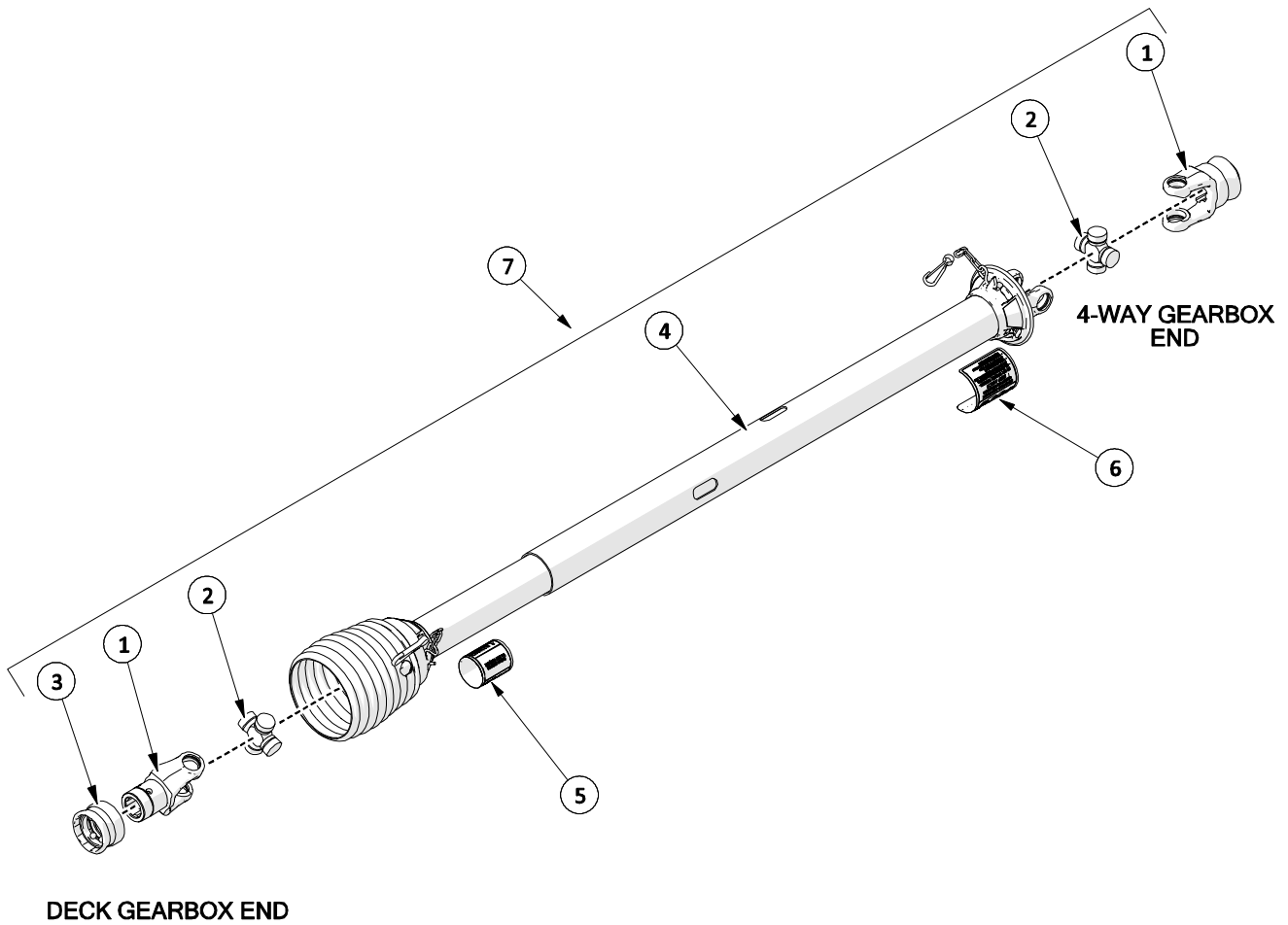

ITEM	PART #	DESCRIPTION	QTY
1	210192	SPRING-LOCK YOKE ASSEMBLY	2
2	210191	U-JOINT KIT	2
3	210196	SPRING-LOCK REPAIR KIT	2
4	210195	COMPLETE GUARD SET	1
5	210239	SAFETY SIGN - INNER GUARD	1
6	210237	SAFETY SIGN - OUTER GUARD	1
7	210190	DECK SHAFT - COMPLETE W/GUARDS	1

4.3 Intermediate PTO Shaft

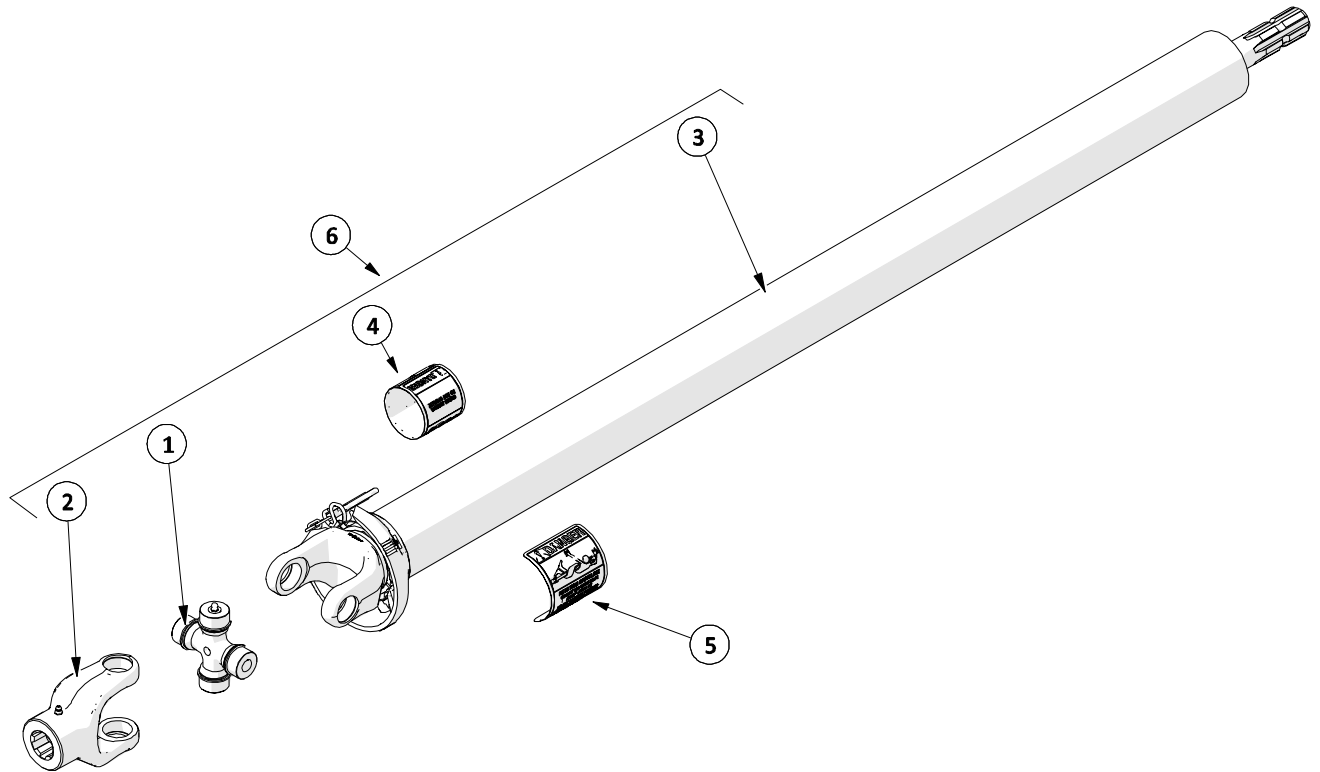

ITEM	PART #	DESCRIPTION	QTY
1	210171	U-JOINT KIT	1
2	210172	SLIDE YOKE	1
3	210173	GUARD SET	1
4	210239	SAFETY SIGN - INNER GUARD	1
5	210237	SAFETY SIGN - OUTER GUARD	1
6	210170	INTERMEDIATE SHAFT - COMPLETE	1

4.4 Input PTO Shaft

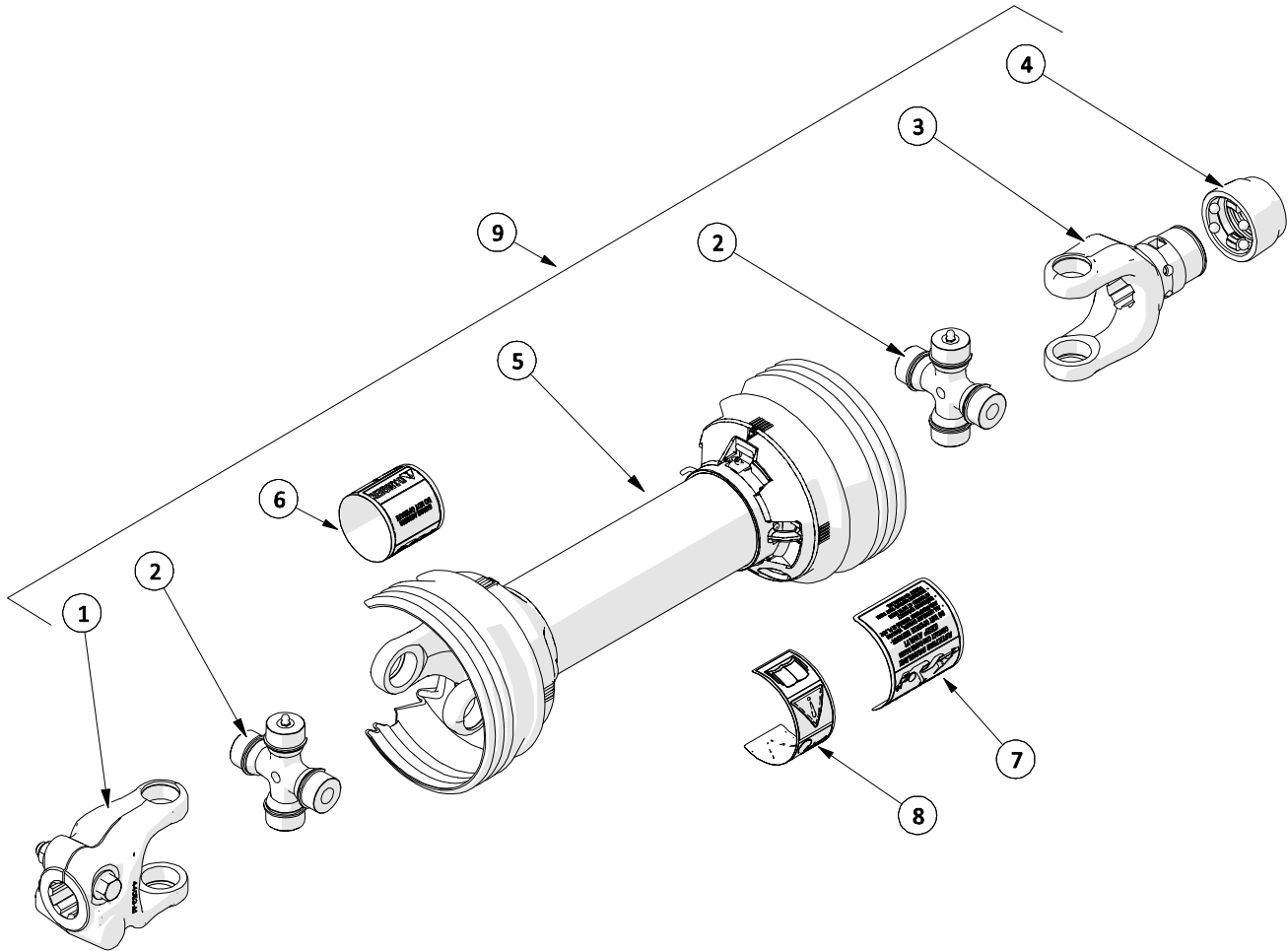

ITEM	PART #	DESCRIPTION	QTY
1	210174	CLAMP YOKE	1
2	210171	U-JOINT KIT	2
3	210175	SLIDE LOCK YOKE ASSEMBLY	1
4	210179	SLIDE LOCK REPAIR KIT	1
5	210178	COMPLETE GUARD SET	1
6	210239	SAFETY SIGN - INNER GUARD	1
7	210237	SAFETY SIGN - OUTER GUARD	1
8	210238	CE WARNING DECAL	1
9	210150	INPUT PTO SHAFT - COMPLETE	1

4.5 Deck Gearbox

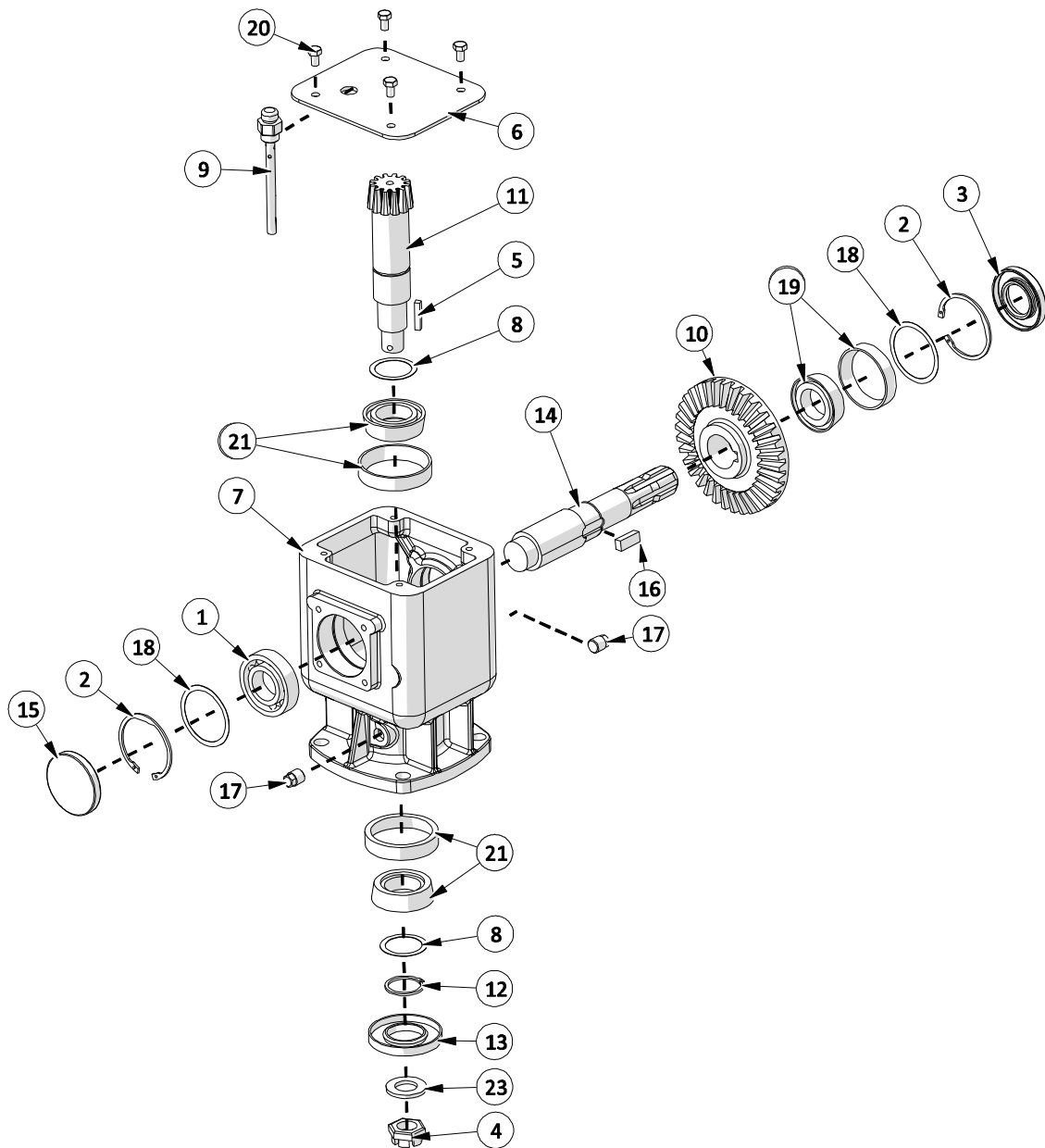

ITEM	PART #	DESCRIPTION	QTY
1	521116	BEARING	1
2	521126	SNAP RING - 3 PC KIT	2
3	521127	OIL SEAL	1
4	521130	CASTLE NUT - M24	1
5	521390	DECK GEARBOX KEY (3 PCS)	1
6	521420	COVER PLATE	1
7	521428	CASING	1
8	521436	SHIM KIT (2 PCS)	2
9	521433	OIL LEVEL DIPSTICK	1
10	521434	GEAR	1
11	521435	PINION SHAFT	1
12	521439	SNAP RING - 3 PC KIT	1

ITEM	PART #	DESCRIPTION	QTY
13	521440	OIL SEAL	1
14	521441	INPUT SHAFT	1
15	521443	CAP	1
16	521444	KEY - 12 X 8 X 30	1
17	521482	HEX PIPE PLUG	2
18	521491	SHIM KIT	2
19	521362	BEARING - TAPERED ROLLER	1
20	521399	BOLT - M8 X 14 - 8.8	4
21	521442	BEARING - 30208	2
23	521129	WASHER KIT (3 PCS)	1
24	521432	GEAR BOX - DECK - COMPLETE	1

4.6 4-Way Gear Box

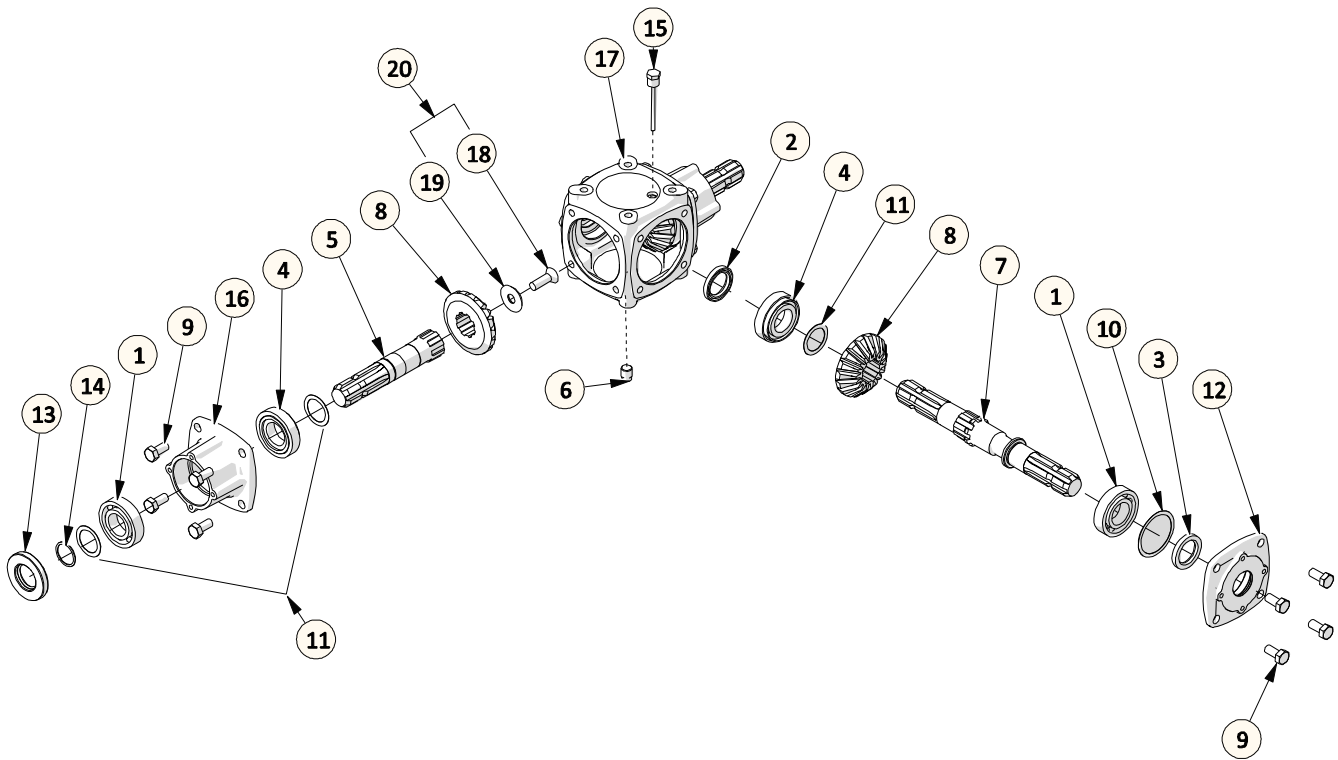

ITEM	PART #	DESCRIPTION	QTY
1	521116	BEARING - 6207	3
2	521120	OIL SEAL	1
3	521120	OIL SEAL	1
4	521362	BEARING - TAPER ROLLER - 7207E	3
5	521481	STUB EXTENSION SHAFT	2
6	521482	HEX PIPE PLUG	1
7	521486	THRU SHAFT	1
8	521487	GEAR (Z18 M5)	3
9	521488	BOLT - M12 X 25 - 8.8 KIT (6 PCS)	2
10	521491	SHIM KIT (3 PCS)	1
11	521794	SHIM KIT - 3 PCS	1
12	521797	COVER	1
13	521127	OIL SEAL	2
14	521137	SNAP RING	1
15	521489	DIPSTICK	1
16	521796	EXTENSION HOUSING	2
17	521483	HOUSING	1
18	-	HEX COUNTERSUNK BOLT - M12 X 40	2
19	-	WASHER	2
20	522426	GEARBOX SHAFT BOLT KIT	1

5 Decals

5.1 Safety

If decals become faded, damaged, or lost, replace immediately. Order decal according to corresponding Part # below. Complete decal kits are also available.

TDR-26 DECAL KIT - 530040

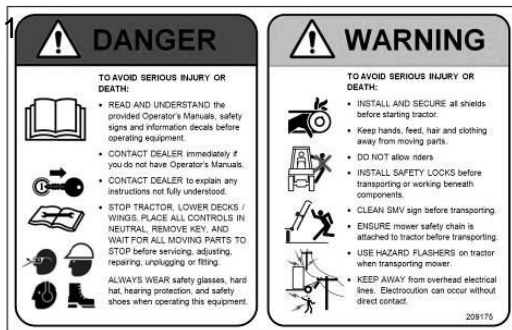

209175
DECAL – GENERAL SAFETY

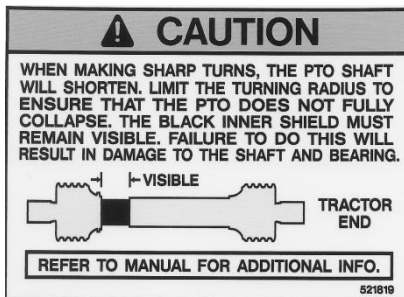

521819
DECAL – CAUTION

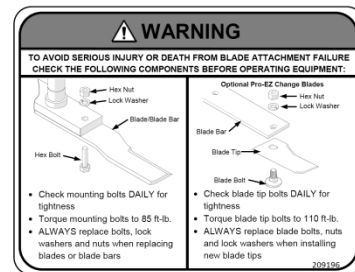

209196
DECAL – BLADE
HARDWARE



209113
DECAL – REPLACE SHIELDS



521820
DECAL – CAUTION



521817
DECAL – PROGRESSIVE
TURF



209103
DECAL – “PROGRESSIVE”



209115
DECAL – OEM PARTS

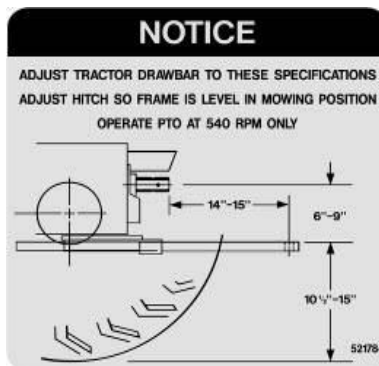

521784
DECAL – NOTICE



209173
DECAL – ROTATING BLADE
DANGER

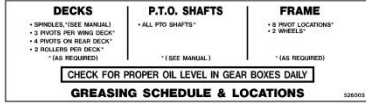

526003
DECAL – GREASING
SCHEDULE

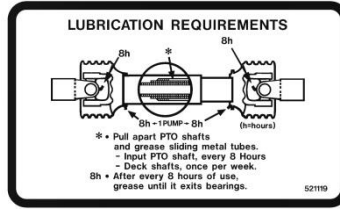

521119
8HR DECAL – PTO GREASE

TDR-26
ROLLER MOWER

209197
DECAL – TDR 26 ROLLER
MOWER

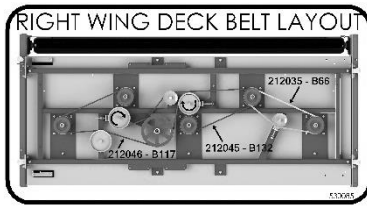

530085
RH WING DECK
BELT LAYOUT

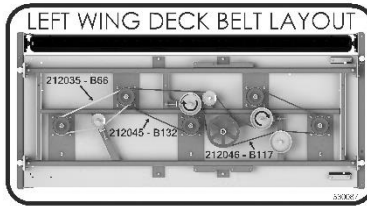

530087
LH WING DECK BELT
LAYOUT

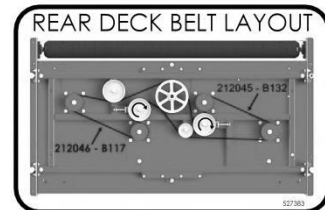

527521
REAR DECK BELT
LAYOUT



210239
DECAL – INNER GUARD



521455
DECAL – OUTER SHIELD



210238
DECAL – CE WARNING



521014
DECAL – GREASE GUN

